

Real-time Digital Signal Processing  
Model: APV8104-14

Instruction Manual

1.1.1 Edition Apr. / 2018

TECHNO AP CO., LTD.

2976-15 Mawatari, Hitachinaka-shi, Ibaraki 312-0012, Japan

TEL. +81-29-350-8011 FAX. +81-29-352-9013

<http://www.techno-ap.com>

## Disclaimer

We thank you for your continued confidence and patronage.  
Thank you very much for truly about using our product.

Take no responsibility in the folling cases of using our product.

- Damage claim about equipment and connection equipment and software damage.
- All of the damage compensation , including secondary damages.

Please use is self-responsibility.

### DON'T

- Please do not use in applications requiring reliability such as related to human life or accident.
- Please do not use in special environment such as high temperature, high humidity, a vibration-prone area.  
(The measures the product is excluded.)
- Please do not turn on the power in a state contacting the metal with the board.
- Please do not apply a voltage exceedin the rating.
- Resale is prohibited.

### CAUTION

- Please immediately turn off the power if smoke or abnormal heat generation.
- It may not work properly in a noisy environment.
- Please be aware of the static electricity.
- The contents of specifications and related document of the product are subject to change without notice.

## Guarantee conditions

Warranty conditions are as follows:

- Warranty period                      Buy after one year.
- Warranty information              If you have trouble in use within the warrantry period,  
We will do the repair or replacement.
- Out of warranty as follows:
  - (1)    If you use in other than the above methods of use.
  - (2)    The trouble due to causes other than our product and natural disaster.
  - (3)    Expendables, etc.

## Contents

1. Abstracts.....	4
1. 1. Specification.....	5
1. 2. System Requirements.....	5
1. 3. Revision History .....	5
2. External .....	6
3. Preparation.....	7
3. 1. Installation of the application.....	7
3. 2. Power ON and IP Connection Confirmation.....	8
3. 3. Display.....	9
4. Screen.....	10
4. 1. Startup Screen.....	10
4. 2. Config Tab.....	12
4. 3. File Tab .....	17
4. 4. Wave Tab.....	18
4. 5. Spectrum Tab.....	20
4. 6. Timespectrum Tab .....	21
5. File.....	22
5. 1. Histogram Data File.....	22
5. 2. Wave Data File.....	24
5. 3. List Data File .....	25
5. 4. List-Wave Data File .....	26
6. Command .....	27
6. 1. General Outline.....	27
6. 2. Command Format .....	28
6. 3. Command Type .....	29
6. 4. Command Table .....	32
6. 5. Description.....	34
6. 6. Command transmission and reception example .....	44

## 1. Abstracts

The APV8104-14 is a waveform analysis board for scintillation detectors. Each channel (4CH) is equipped with high-speed, high resolution ADC (1GHz, 14 bit). The APV8104-14 can correspond to the high rates of more than 200 kcps per CH in the list mode with using the Gigabit Ethernet (Gb Ether) connection.

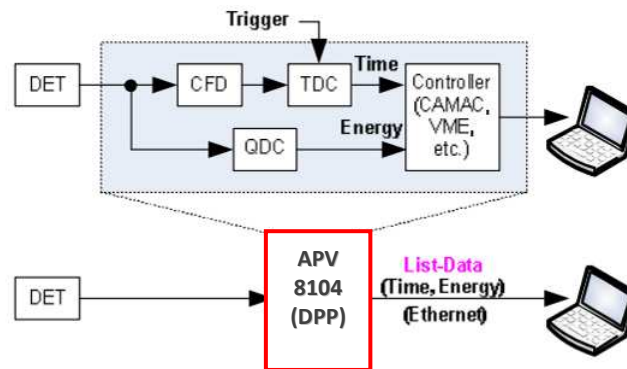

Fig. 1-0-1. DPP structure

※In this instruction manual, “List” and “Event” are equivalences.

※In this instruction manual, “Histogram” and “Spectrum” are equivalences.

## 1. 1. Specification

---

### (1) Analog Input

- Number of Channel : 4CH
- Input Range :  $\pm 1V$
- Coarse Gain : 1x, 3x
- Input Impedance : 50  $\Omega$

### (2) ADC

- Sampling Frequency : 1GHz
- Resolution : 14bit
- SNR : 68.3dBFS@605MHz

### (3) Performance

- QDC Throughput : More than 1Mcps
- Time Resolution : 3.9ps(LSB)

### (4) MCA

- Measurement Mode : Wave Mode, Histogram Mode, List Mode, Wave-List Mode
- Event Transmission Rate : Approx. 10Mbyte / sec. In case of 10Byte (80Bit) / Event, CH total is 1Mcps.

### (5) I/F

- LAN I/F : Ethernet TCP/IP1000Base-T (List data acquisition), UDP/IP (config data, states data sent / received)

### (6) Form

- VME type : APV8104-14(4CH)

### (7) Wattage

- +5V : 3.5A (Max.)
- +12V : 0.8A (Max.)
- 12V : 0.4A (Max.)

## 1. 2. System Requirements

---

- Microsoft Windows 7 or later

## 1. 3. Revision History

---

Nov./01/2016	1.0.0	First Edition
Dec./01/2017	1.1.0	Added TimeSpectrum Tab

## 2. External

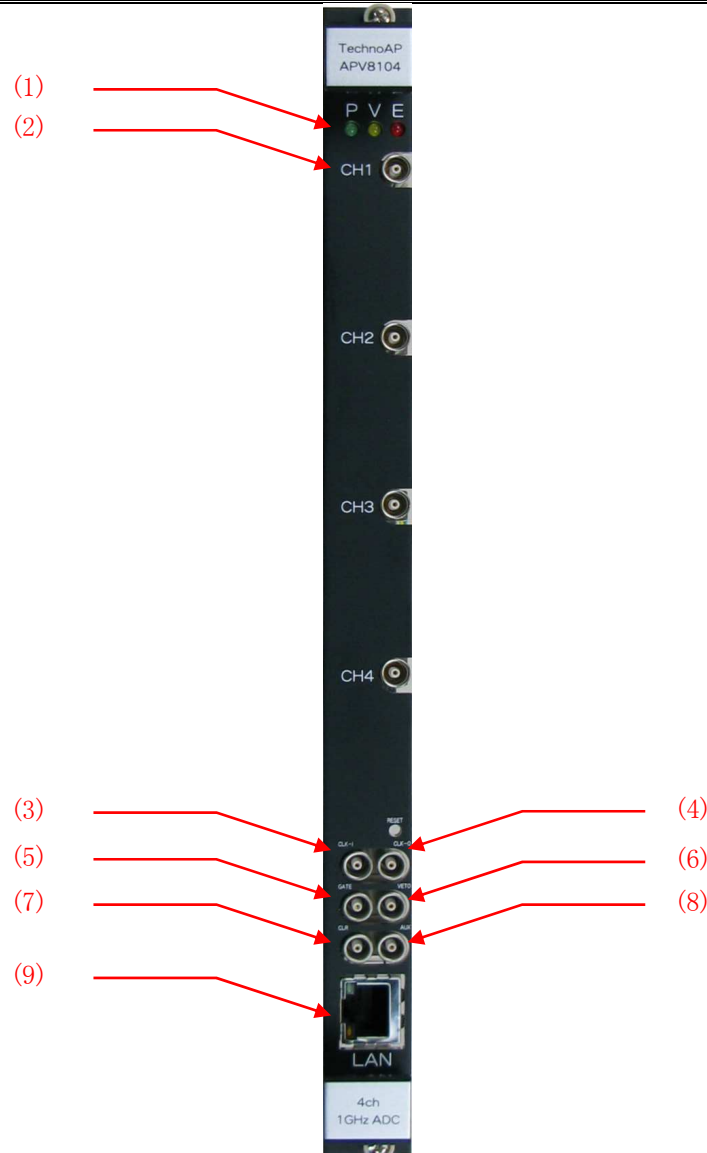

- |             |  |
|-------------|--|
| (1) LED     | Turn on a power; light a red lamp.   |
| (2) CH1~CH4 | LEMO00 series connector for signal input.  |
| (3) CLK-I   | LEMO00 series connector for external signal (TTL Signal) input. APV8104 work with external clock. Turn on the power after input of 25MHz of theTTL signal.     |
| (4) CLK-O   | LEMO00 series connector for external signal (TTL Signal) output. This connector outputs the 25MHz of the TTL signal.   |
| (5) GATE    | LEMO00 series connector for external signal (TTL Signal) input. This connector enter the GATE signal. You can acquire the data while input is high.            |
| (6) VETO    | LEMO00 series connector for external signal (TTL Signal) input. “This connector enter the VETO signal. To disable the date acquisition when the input is high. |
| (7) CLR     | LEMO00 series connector for external signal (TTL Signal) input. It clears the time counter data on the rising edge of ‘high’.                                  |
| (8) AUX     | LEMO00 series connector for external signal (TTL Signal) output. If signal is detected, output TTL signal.   |
| (9) LAN     | RJ45 connector for Ethernet.   |

## 3. Preparation

### 3. 1. Installation of the application

Application is upgraded. You are able to install application after uninstall current application.

(1) Recommended computer environment is below.

Microsoft Corp. Windows 7 32Bit, screen resolution XGA(1024×768) or more.

(2) Log in with administrative privileges.

(3) Insert the installation CD to your computer. Run 「Installer」 folder 「setup.exe」.

(4) After finished of installation, restart PC.

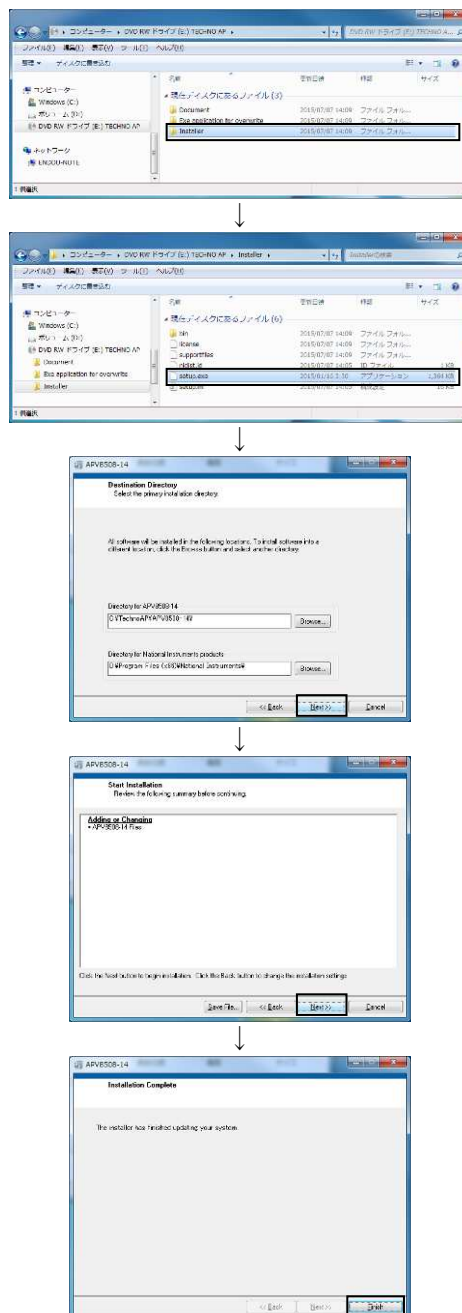

Uninstall is 「Start- Control panel - Add or Remove Programs.

## 3. 2. Power ON and IP Connection Confirmation

- (1) Confirm power on the PC and Hub, and ON the VME power switch.
- (2) Please wait 30 second
- (3) Start the windows application “cmd.exe”. Confirm Ethernet connection as follows.  
「ping 192.168.10.128」

### ※Case of success

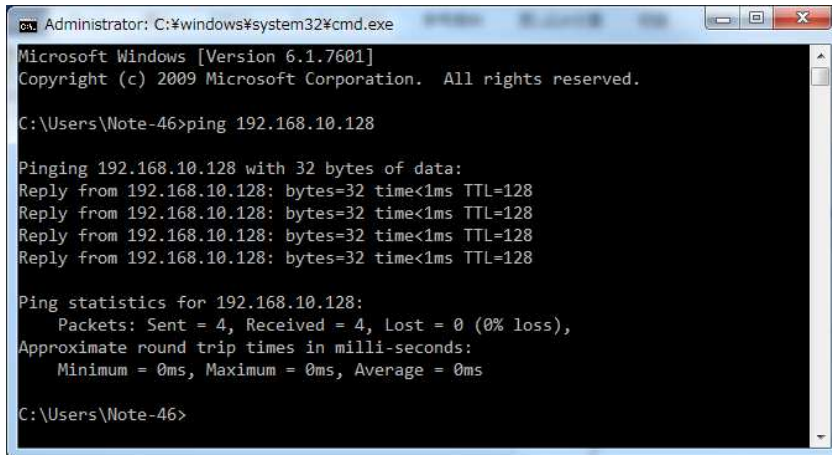

```
Administrator: C:\windows\system32\cmd.exe
Microsoft Windows [Version 6.1.7601]
Copyright (c) 2009 Microsoft Corporation. All rights reserved.

C:\Users\Note-46>ping 192.168.10.128

Pinging 192.168.10.128 with 32 bytes of data:
Reply from 192.168.10.128: bytes=32 time<1ms TTL=128
Reply from 192.168.10.128: bytes=32 time<1ms TTL=128
Reply from 192.168.10.128: bytes=32 time<1ms TTL=128
Reply from 192.168.10.128: bytes=32 time<1ms TTL=128

Ping statistics for 192.168.10.128:
    Packets: Sent = 4, Received = 4, Lost = 0 (0% loss),
    Approximate round trip times in milli-seconds:
        Minimum = 0ms, Maximum = 0ms, Average = 0ms

C:\Users\Note-46>
```

### ※Case of failure

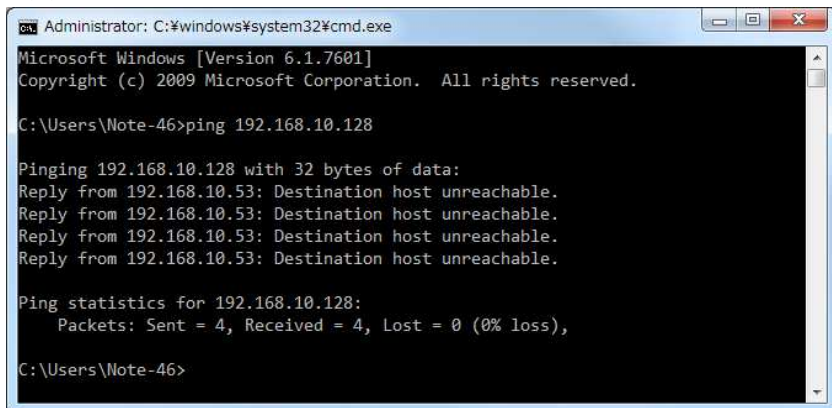

```
Administrator: C:\windows\system32\cmd.exe
Microsoft Windows [Version 6.1.7601]
Copyright (c) 2009 Microsoft Corporation. All rights reserved.

C:\Users\Note-46>ping 192.168.10.128

Pinging 192.168.10.128 with 32 bytes of data:
Reply from 192.168.10.53: Destination host unreachable.
Reply from 192.168.10.53: Destination host unreachable.
Reply from 192.168.10.53: Destination host unreachable.
Reply from 192.168.10.53: Destination host unreachable.

Ping statistics for 192.168.10.128:
    Packets: Sent = 4, Received = 4, Lost = 0 (0% loss),

C:\Users\Note-46>
```



(4) Start application 「APV8104-14」.

※When it fail to start application, display as follows message.

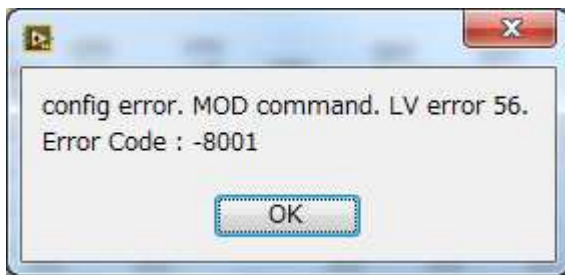

※It will show the main cause below.

- It is insufficient insertion of LAN cable.
- PC network setting is “DHCP”.
- IP address of TCP/IPv4 is not the range ”192.168.10.2” to “192.168.10.255”.

※Please try again following.

- After application is closed, it will restart the VME power.
- Confirm connection of “EXT clock”.

### 3. 3. Display

---

Recommended monitor resolution is more than XGA(1024x768).

## 4. Screen

### 4. 1. Startup Screen

The following opening screen is displayed when you carry out “Start”-“TechnoAP”-“APV8104-14”.

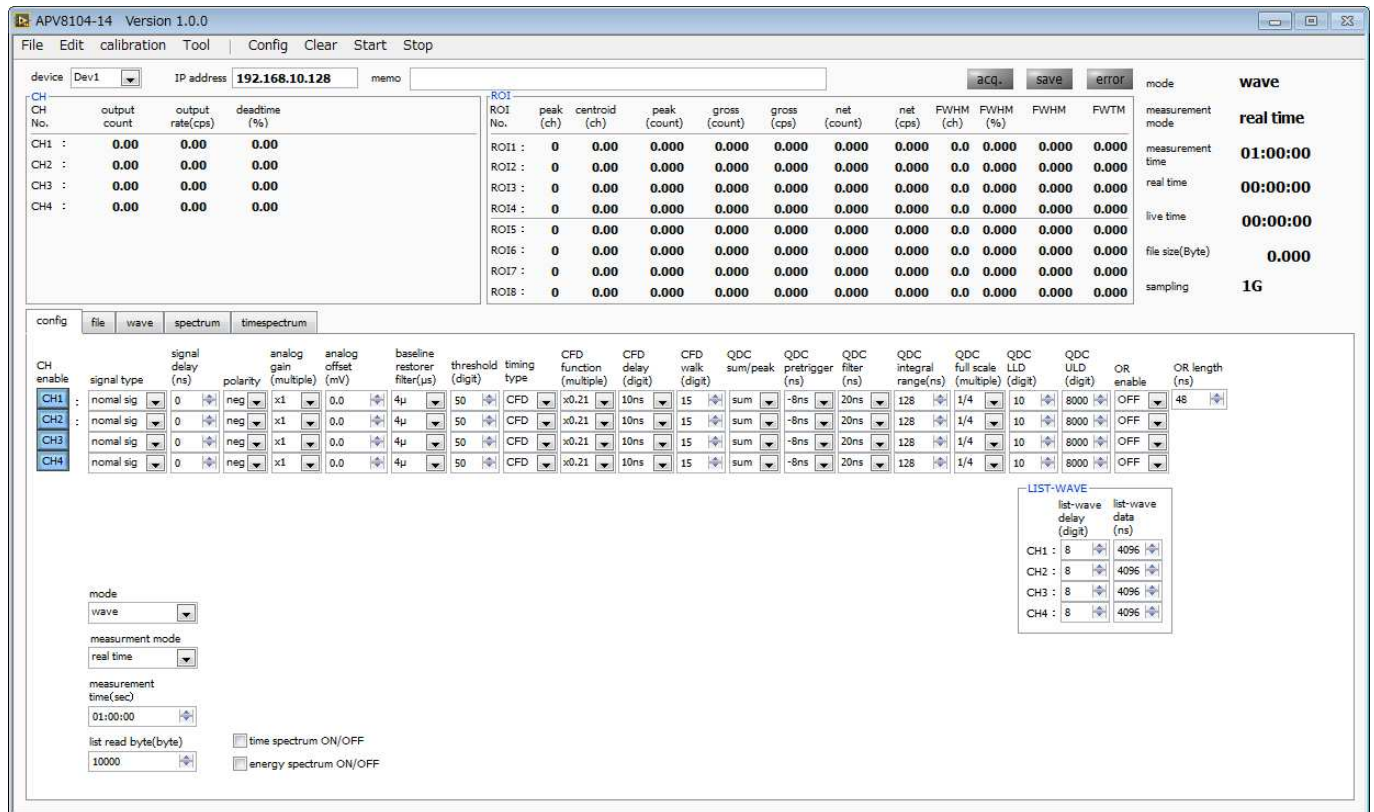

Fig. 4-1-1 DPP MCA Start screen

The following description is about Start screen.

#### •Menu

The configuration of “File”, “Edit”, “Config”, “Clear”, “Start”, “Stop”.

- “File”-“open config” : Reading of the config file
- “File”-“save config” : Save current setting in a config file
- “File”-“save histogram” : Save current histogram data in a file
- “File”-“save wave” : Save the wave data
- “File”-“save image” : Save the DPP MCA screen in PNG format image
- “File”-“quit” : Quit of the application
- “Edit”-“copy setting of CH1” : Setting of CH1 in the “CH” tab is reflected by setting of all other CH
- “Edit”-“IP configuration” : Change IP address of current display device
- “Edit”-“calibration” : Calibrate the device
- “Edit”-“instruction manual” : Open the instruction manual in PDF format.
- “Tool”-“Auto threshold” : Auto threshold.
- “Tool”-“Auto walk” : Auto walk.
- “Help” : Open the instruction manual of current tab in PDF format
- “Config” : Send all setting to DPP
- “Clear” : Initialize histogram data in DPP
- “Start” : Send “Measurement start” to DPP
- “Stop” : Send “Measurement stop” to DPP

#### •Tab

- “config” : DPP setting and Setting about the measurement

- 
- “File” : Setting of waveform and save of list data
  - “wave” : Display of input waveform, CFD waveform and QDC waveform
  - “spectrum” : Display of histogram from QDC of list data
  - “timespectrum” : Display a time lag spectrum of CH1 and CH2 from time information of list data
- CH
- Display a state each CH.
- “output count” : Output total count. Output event number of total.
  - “output rate (cps)” : Output count rate. Number of the output events / second.
  - “deadtime (%)” : Deadtime ratio
- ROI
- Display a calculation result between ROI.
- “peak (ch)” : CH of the maximum count
  - “centroid (ch)” : Calculated center value (CH) by the total of all counts
  - “peak (count)” : Maximum count
  - “gross (count)” : The sum of the count between ROI
  - “net (count)” : The sum of the count obtained by subtracting the background between the ROI
  - “net (cps)” : Count of CPS obtained by subtracting the background between the ROI
  - “FWHM (ch)” : Half Width at Half Maximum (ch)
  - “FWHM (%)” : Half Width at Half Maximum (%).  
Half Width at Half Maximum / ROI Definition Energy x 100
  - “FWHM” : Half Width at Half Maximum
  - “FWTM” : 1/10 width
- Device : Choose the DPP for targeted measurement.
  - IP Address : IP address. IP address of the selected device will be display
  - Memo : You can enter notes
  - Acq. LED : Blinking LED when during measure.
  - Save LED : Blinking LED when during save List Data.
  - Error LED : Blinking LED when during occurrence of an error.
  - Mode : “hist”, “wave” and “list”
  - Measurement Mode : Measurement Mode; “Real Time”, “Live Time”
  - Measurement Time : It is the measurment time set
  - Real Time : It is a measurement time of the first CH.
  - Live Time : It is a live time of the first CH. Live time = real time - dead time
  - File Size (Byte) : It is a capacity of the list mode saved current file

## 4. 2. Config Tab

Fig. 4-2-1 Config Tab

- Enable : Please enable all CH
- Signal Type : This select the type of the input waveform. Fast rise of the signal, please to NIM signal setting. For example, NIM signal and 4ns following the rising edge.
- Polarity : This select the polarity of the input signal.
- Analog Gain : Choose the Analog Gain, 1x, 3x.
- Analog Offset : Choose the Analog Offset. The range is  $\pm 1000\text{mV}$ . Nomally set 0.0mV.
- Baseline Restorer Filter: This set the time constatat of the baseline restorer filter. Ext (AutoBLR off)、Fast、 $4\mu\text{s}$ 、 $85\mu\text{s}$ 、 $129\mu\text{s}$ 、 $260\mu\text{s}$ . Nomally set to  $85\mu\text{s}$ .
- Threshold : Set the threshold. Unit is digit. Range is 0 to 8191.

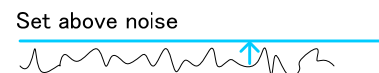
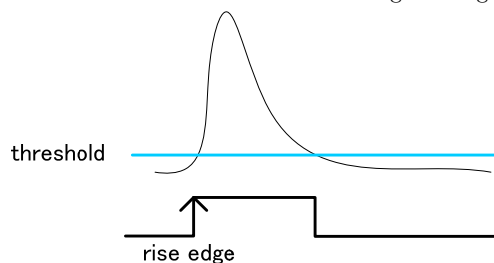

•CFD Function : This magnification use to reduce the input signal. Set value is  $\times 0.03$ ,  $\times 0.06$ ,  $\times 0.09$ ,  $\times 0.12$ ,  $\times 0.15$ ,  $\times 0.18$ ,  $\times 0.21$ ,  $\times 0.25$ ,  $\times 0.28$ ,  $\times 0.31$ ,  $\times 0.34$ ,  $\times 0.37$ ,  $\times 0.40$ ,  $\times 0.43$ ,  $\times 0.46$ .

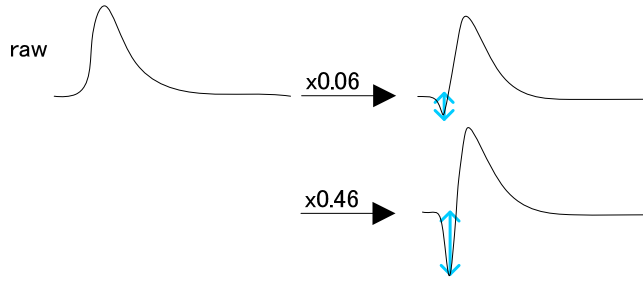

•CFD Delay : Set the time of delay for CFD signal generation. Set value is 1ns to 24ns every 1ns.

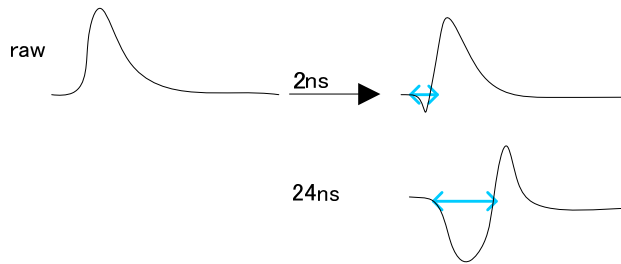

•CFD Walk : Set the value for timestamp. Nomally set 15 digits.

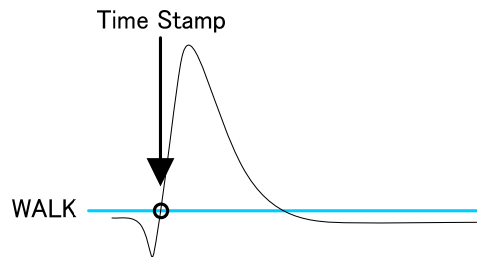

•QDC Sum or Peak : Set the type of QDC data. Type select from the PEAK and SUM. PEAK is the peak value of raw signal. SUM is the integral value of QDC waveform.

In case of setting 'peak',  
QDC is peak value.

In case of setting 'sum',  
QDC is integral value.

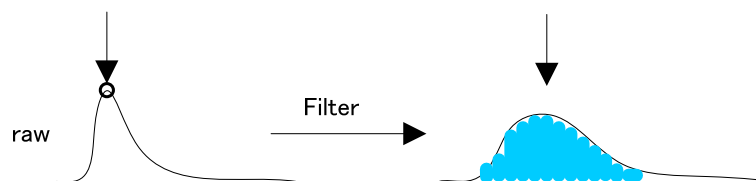

•QDC Pretrigger : Set the time of the integral start point for QDC waveform. Value select 0ns, -8ns, -16ns, -32ns, -40ns, -48ns, -56ns, -60ns.

The Integration start point is  
setted depending on 'pretrigger'.

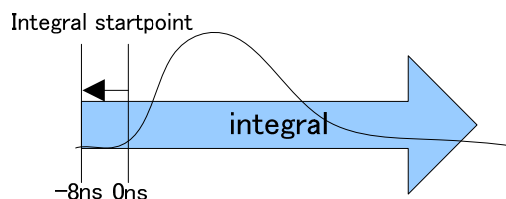

- QDC Filter : Set the time constant of QDC waveform generation. Value select Ext, 10ns, 20ns, 50ns, 100ns, 200ns

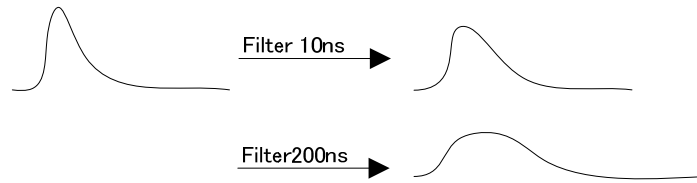

- QDC Integral Range : Set the integral time of QDC waveform. Range is 0ns from 32000ns.

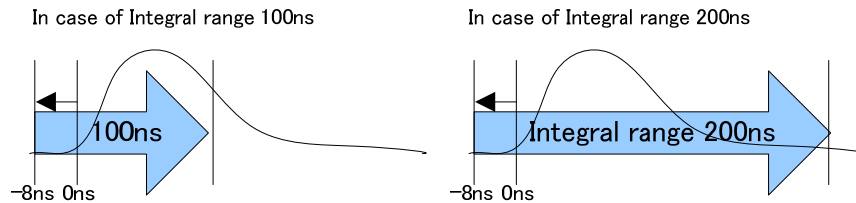

- QDC Full Scale : Set the gain of QDC integral value. Value select 1/1, 1/2, 1/4, 1/8, 1/16, 1/32, 1/64, 1/128, 1/256, 1/512.

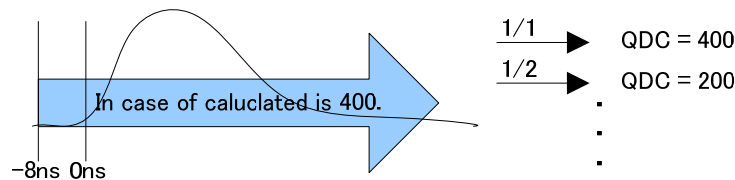

- QDC LLD : Set the LLD(Lower Level Discriminator) of QDC. It does not get the time stamp data and QDC integral data if the QDC integral data smaller than LLD. Please set LLD smaller than ULD. Range is 0 from 8191 digit.
- QDC ULD : Set the ULD(Upper Level Discriminator) of QDC. It does not get the time stamp data and QDC integral data if the QDC integral data greater than ULD. Range is 0 from 8191 digit.
- Timing Type : Select the waveform for time stamp. You can select the CFD waveform and the LED (raw) waveform.  
 “LET” : Leading Edge Timing  
 It is the timing that has been reached to trigger. Timestamp timing is different by the signal height.

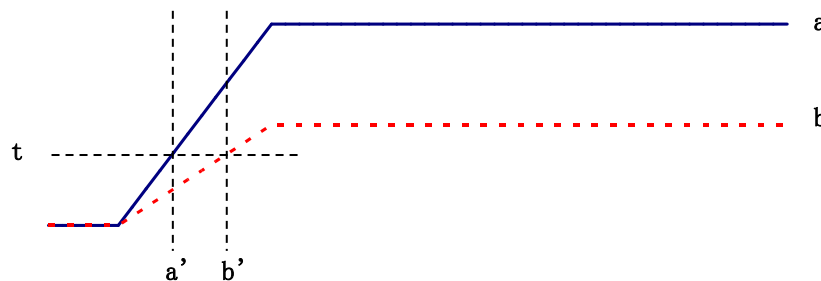

Fig. 4-2-2 How to use Leading Edge Timing

“CFD” : Constant Fraction Discriminator Timing

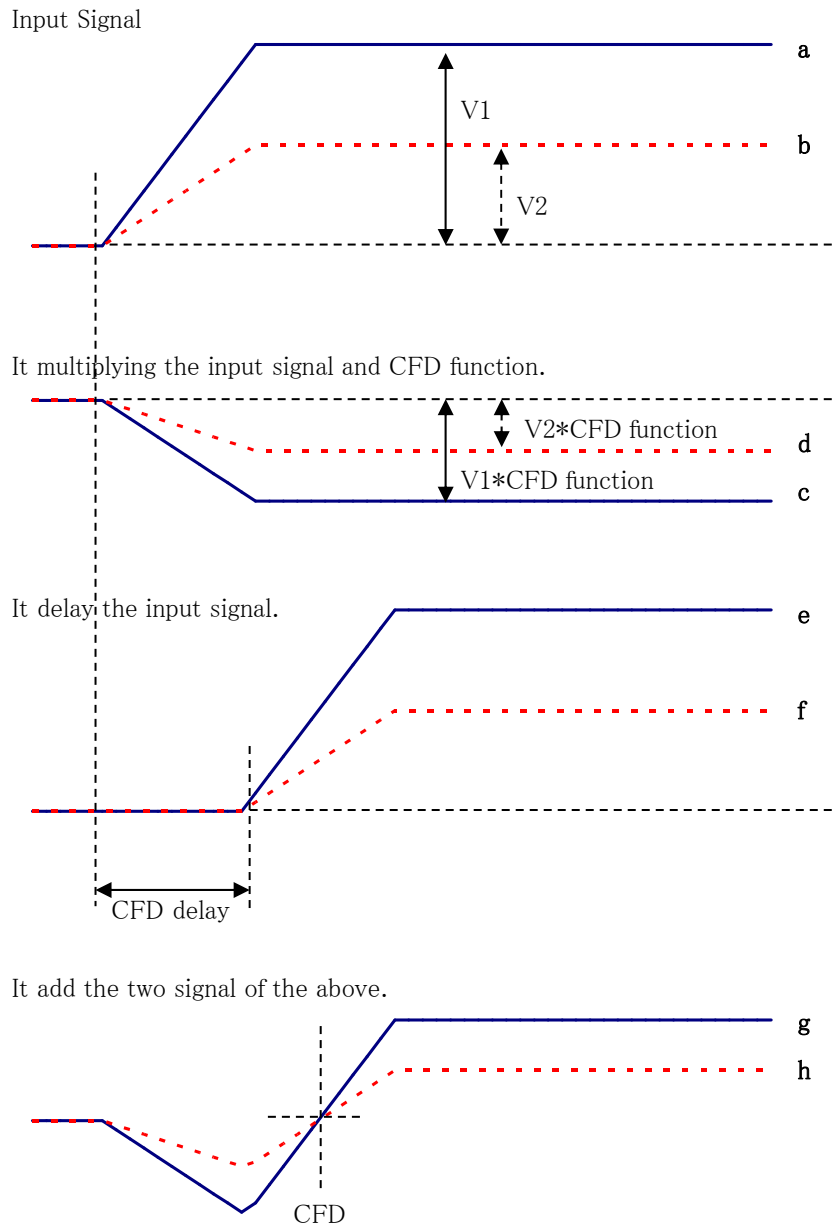

Fig. 4-2-3 How to use Constant Fraction Discriminator Timing

Timestamp timing is the same by CFD wave generation.

c, d : a and b multiplying the input signal and CFD function.

e, f : a and b delay the setting value.

g, h : it sam the each wave.

Features of CFD wave form is the same even though different wave high.

- 
- OR-enable : If it is enable, TTL signal is outputted from lemo-connect at front panell every signal detected.
  - OR-length : You can set length of TTL signal about OR output function. Setable range is 8ns to 1000ns.
  - list-wave delay : When list-wave mode, you can adjust the wave position. Nomaly it set 8digit. Range is 0 to 30 digit.
  - list-wave data : When list-wave mode, you can set wave data leangth. Setable range is 40 point to 4096 point.  
1point is 1ns.
  - Mode : Choose the mode; Hist Mode, List Mode, Wave Mode and List-Wave Mode.  
(List-Wave Mode is optional setting.)
  - Mesurement Mode : Choose the measurement mode; Real Time, Live Time. Measurement is ended by a time of measurement mode.
  - Mesurement Time : Set the measurement time. Max value is 8760 hours.
  - Read Event Num : The set the unit read number. Normally set 10,000. When the count rate is small, you can set a smaller value.
  - Time Spectrum On/Off : Select the enable of the time spectrum. Please do not ON If you want to get only the list data. If you ON at the high rate count, the acquisition of data is slow.
  - Energy Spectrum On/Off : Select the enable of the energy spectrum. Please do not ON If you want to get only the list data. If you ON at the high rate count, the acquisition of data is slow.



## 4. 3. File Tab

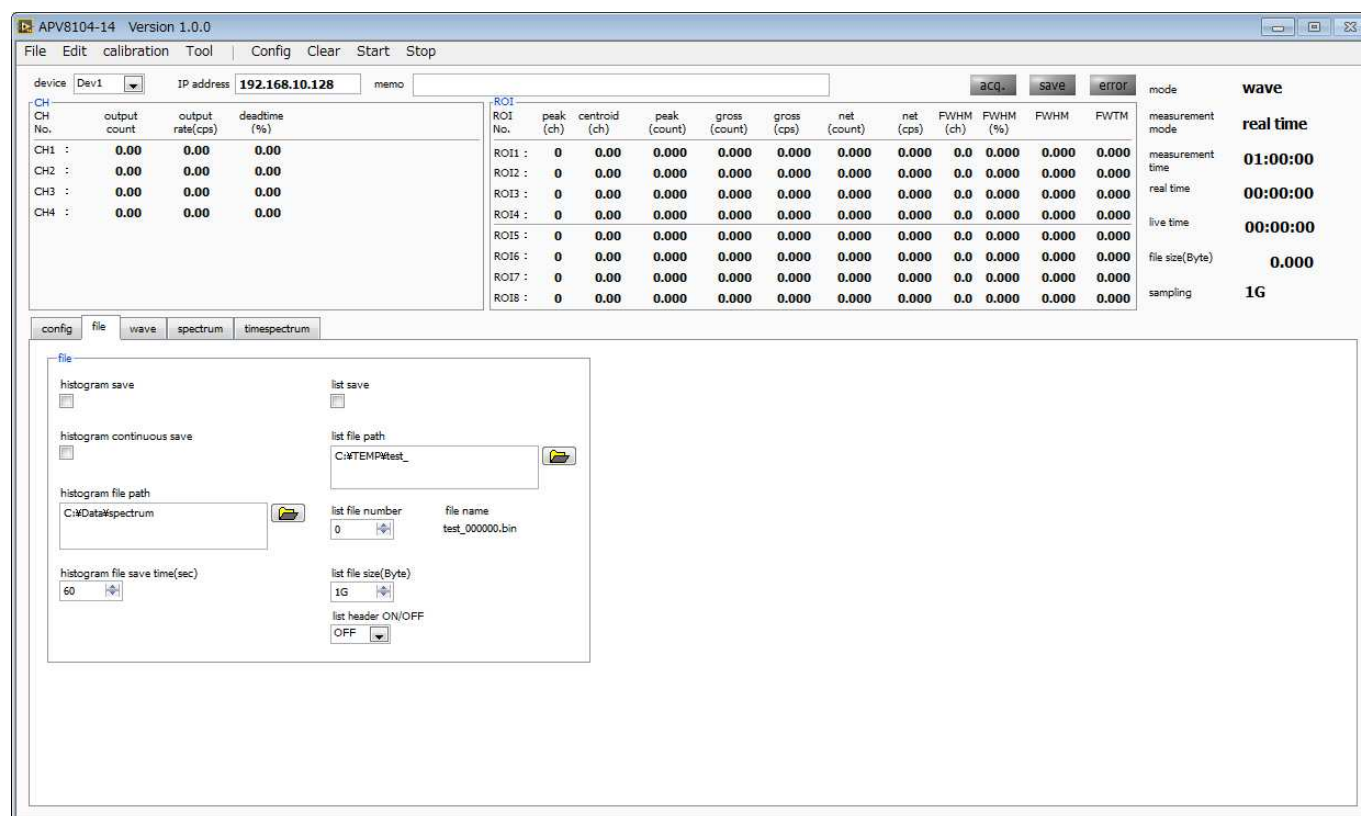

Fig. 4-3-1 File Tab

- Histogram Save : It will save the histogram data at the time of measurement end. It is enable when 「mode」 select 「hist」.
- Histogram Continuous Save : It can select the enable of continues save at the set time intervals. It is enable when 「mode」 select 「hist」.
- Histogram File Path : Set the absolute path of the histogram data. You can also choose not to extension.  
 ※Caution※  
 File name format is as follow.  
 example :  
 「histogram file path」 set 「C:¥Data¥histogram.csv」, 「histogram file save time(sec)」 set 「10」, date is 2010/09/01 and 12:00:00.  
 File name format of the start is 「C:¥Data¥histogram\_20100901\_120000.csv」.  
 After 10 second is 「C:¥Data¥histogram\_20100901\_120010.csv」.  
 ※It may be off by one second increments.
- Histogram File Save Time (sec) : Set the time interval of continue save of histogram data. Unit is second. Range is 3600 second from 5 second.
- List Save : Choose whether you want to save the data. It is enable when 「mode」 select 「list」.
- List File Number : Set the start value of the list data number. Range is 999999 from 0. It will return to 0 if it exceeds 999999.
- List File Size (Byte) : Set the maximum value of the list data file size.  
 If the file size exceed this size, file will close. And it will continue the file save after the file number increment.
- list header ON/OFF : Set the ON/OFF of the list data header. Header is IP address. When it set OFF, the list data nothing include the header.

## 4. 4. Wave Tab

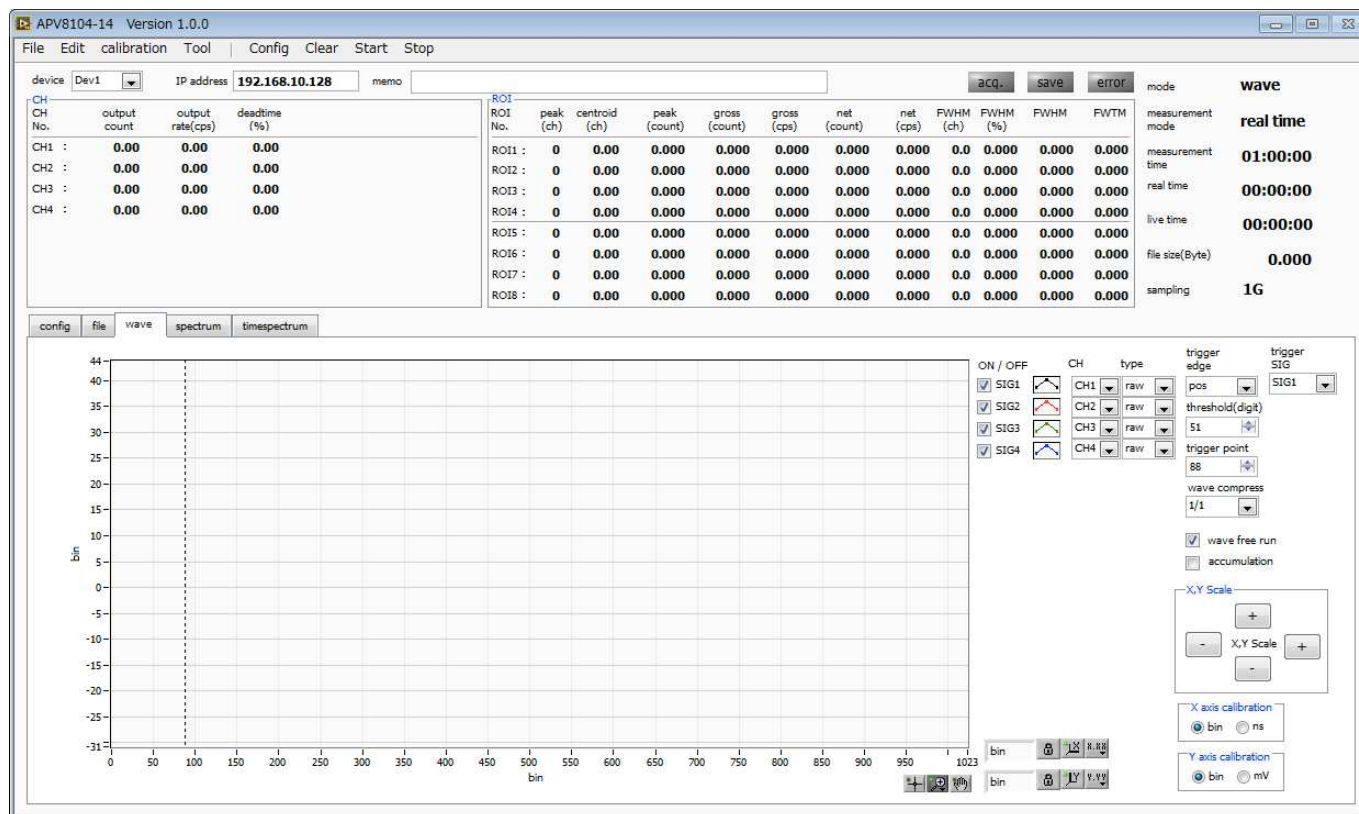



Fig. 4-4-1 wave tab

- Graph : Waveform graph.  
It is enable when 「mode」 select 「wave」.
- On/Off : Select the ON/OFF of the wave display. APV8104 can display the 4 waveform.
  - CH : Select the CH of the waveform display.
  - Type : Select the type of the waveform display.  
「raw」 — ‘raw’ is the raw waveform that was BLR processing.  
「CFD」 — ‘CFD’ is the CFD waveform that was CFD shaping.  
「Filter」 — ‘Filter’ is the waveform tha was the filter shaping.
  - Trigger Edge : Select the polarity of the trigger. Nomally set the ‘pos’.
  - Threshold : Set the threshold value of the trigger. Set is possible by moving the cursor in the graph.
  - Trigger Point : Set the start point of the display waveform. Set is possible by moving the cursor in the graph.
  - Trigger SIG : Select the SIG of the trigger. Nomally set the ‘SIG1’.
  - Wave Free Run : ‘ON’ is displayed the waveform of the trigger free. ‘OFF’ is displayed the waveform of the triggered.
  - Accumulation : Select the accumulation of the waveform.
  - XY Scale : Adjust ‘Xscale’ and ‘Yscale’ at the button. Extension is ‘+’. Reduction is ‘-’.
  - X Axis Calibration : Select the unit of ‘X-axis’.
  - Y Axis Calibration : Select the unit of ‘Y-axis’. ※ ‘mV’ is a reference value.
- X Axis Range : Dialog will be displayed if you right-click on the graph. 「自動スケール」 is auto scale. If you want to change the minimum or maximamu value, placed the mouse pointer on top of the numerical value, it can be changed by clicking or double-click.
  - Y Axis Range : Dialog will be displayed if you right-click on the graph. 「自動スケール」 is auto scale. If you want to change the minimum or maximamu value, placed the mouse pointer on top of the numerical value, it can be changed by clicking or double-click.
  -  : This is tool of the cursor moving. It can move the ROI cursor on the graph if you want to set the ROI.
  -  : This is zoom. It can select the zoom type as the follow.

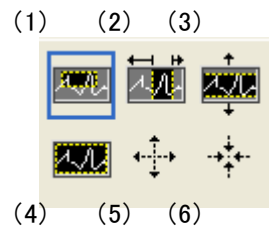

Fig. 4-4-2 zoom in or zoom out Tool

- (1) Tetragon : It surrounds the area using the mouse. And it will be zoom.  
 (2) X-Zoom : This will zoom along the X-axis.  
 (3) Y-Zoom : This will zoom along the Y-axis.  
 (4) Fit Zoom : This will be auto scale.  
 (5) Zoom out to center a point : Click a center point of the zoom out.  
 (6) Zoom in to center a point : Click a center point of the zoom in.



: Pan tool. It can move the graph by this icon.

## 4. 5. Spectrum Tab

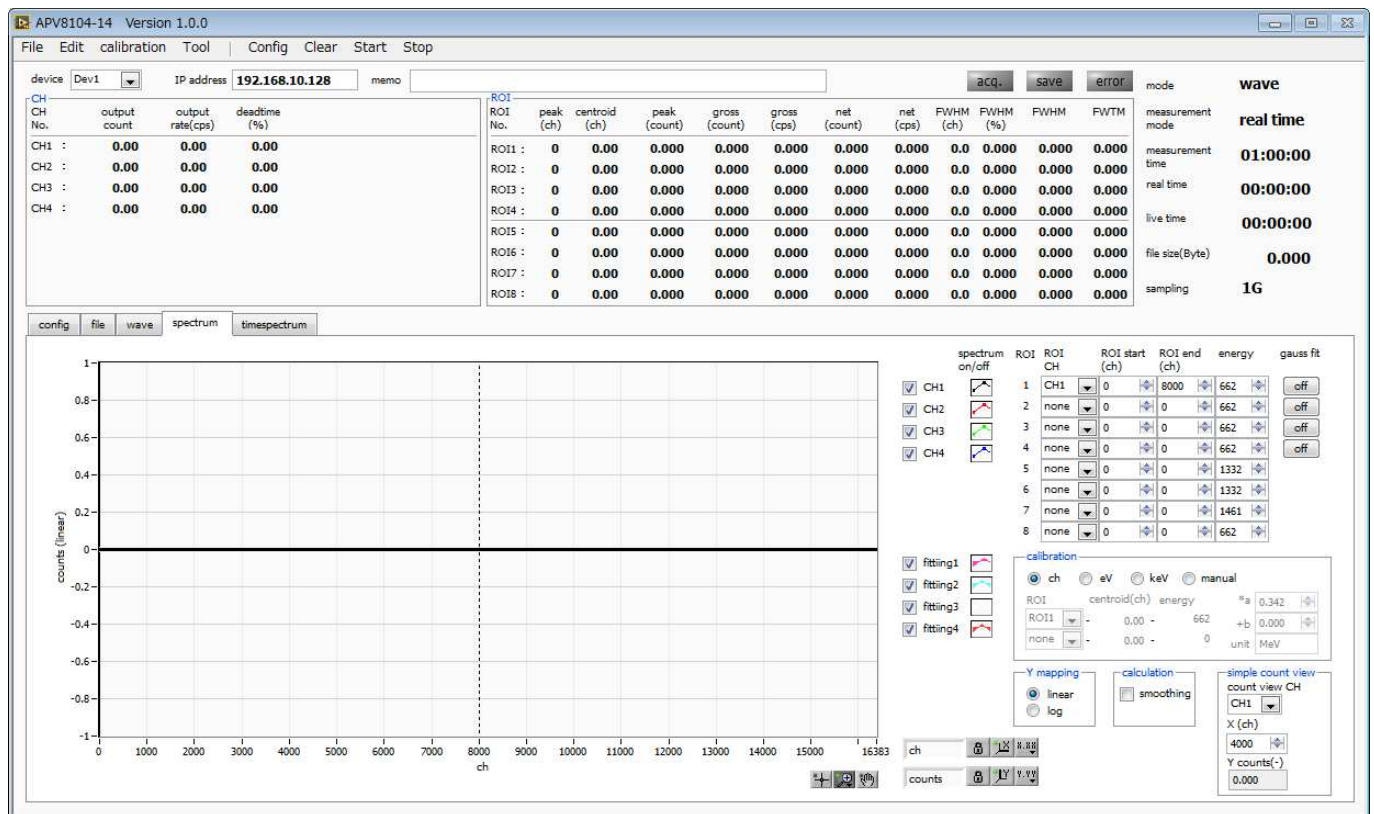

Fig. 4-5-1 Spectrum Tab

- Graph : Energy Spectrum  
It is enable when 「mode」 select 「hist」 or 「list」. If 「mode」 is 「list」, you need to ON of 「spectrum ON/OFF」.
- Check BOX : It make the setting of wether or not to display the histogram of each CH in the graph.
- ROI CH : Set the CH of the ROI. It can set the maximum eight ROI per a CH.
- ROI Start (ch) : Set the start point of the ROI. Unit is ch.
- ROI End (ch) : Set the end point of the ROI. Unit is ch.
- Energy : It define the energy value of the peak ch. Example  $^{60}\text{Co}$  set 1173(keV) or 1332(keV).  
If set 「ch」 of 「calibration」, it will detect the peak between the ROI. The FWHM is calculate by the peak and the energy.
- Calibration : Select the unit of X-axis. X-axis Label will be changed by the setting.
- ch : Display unit is ch.
- eV : Display unit is eV. If you set the two ROI, it run a two-point calibration. X-axis will be converted to the unit eV by the slope and intercept of the primary function  $y=ax+b$ .
- keV : Display unit is KeV. If you set the two ROI, it run a two-point calibration. X-axis will be converted to the unit KeV by the slope and intercept of the primary function  $y=ax+b$ .  
Example:  
If 5717.9ch is 1173.24keV of  $^{60}\text{Co}$  and 6498.7ch is 1332.5keV of  $^{60}\text{Co}$ , it be calculated 0.20397 of slope and 6.958297 of intercept.
- manual : You can set manual value of the slope and the intercept.
- Y mapping : Select the mapping of Y-axis. Y-axis Label will be changed by the setting.
- Linear : Linear
- Log : Log
- Smoothing : This is a smoothing function if the statistics are less. You can get a FWHM faster than nomal.
- Simple count view : Set the view CH and x-ch. Count will be displayed.
- Gauss fit : It runs a Gaussian fit between ROI.

## 4. 6. Timespectrum Tab

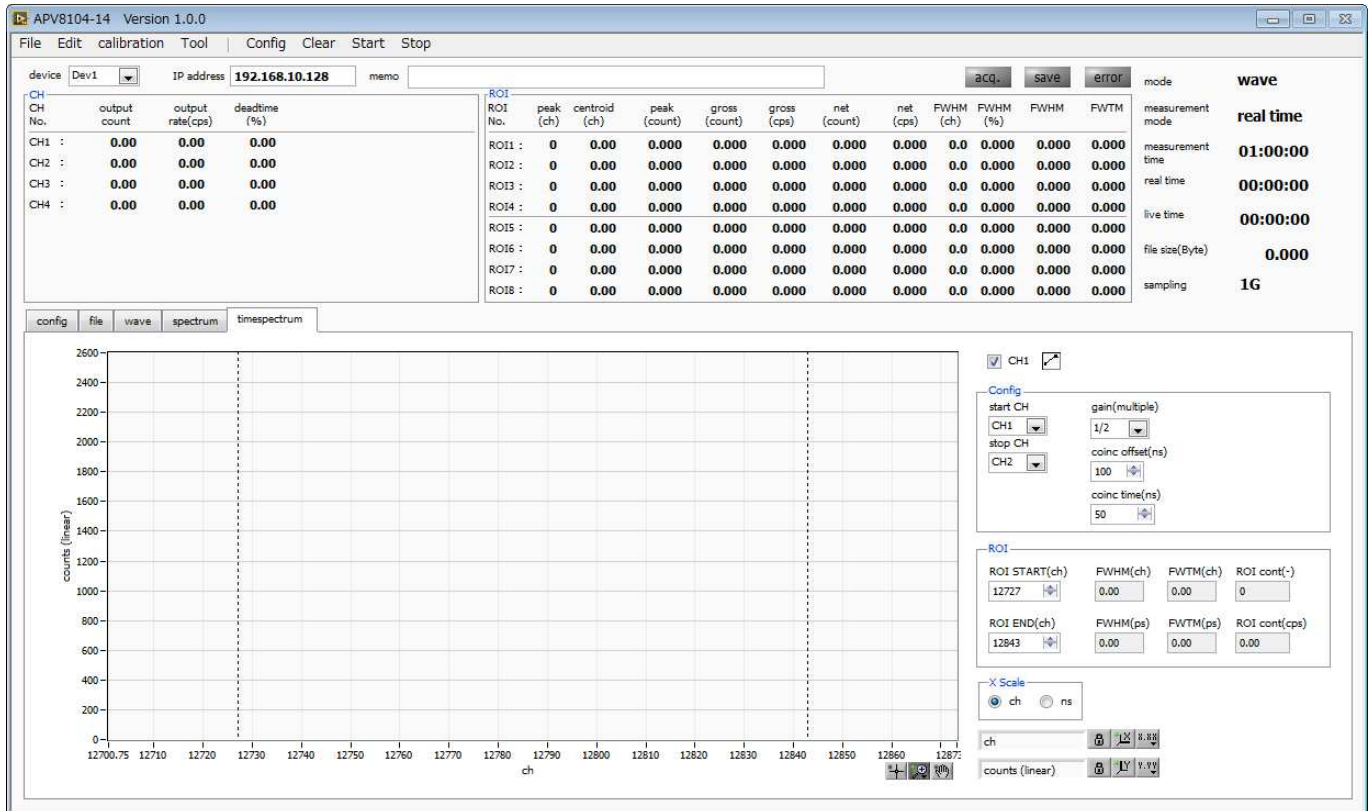

Fig. 4-6-1 Timespectrum Tab

- Graph : Graph is timespectrum.  
It is enable when 「mode」 select 「list」. You need to ON of 「timespectrum ON/OFF」.
- Check BOX : It make the setting of wether or not to display the timespectrum in the graph.

Config : This area is setting value.

Start CH : Start CH

Sotp CH : Stop CH

Gain : 1x from 1/128x

At the time of 1time, full scale about 390 ns (about 3.9ps per 1digit). The 1/128 time full scale about 50  $\mu$ s ( about 0.5 ns per 1digit).

Coinc Offset : Set an offset at 1ns unit.

Coinc Time : Set an coincidencetime at 1ns unit.

ROI : It is setting about calculation.

ROI START : It is the start point of the ROI.

ROI END : It is the end point of the ROI.

FWHM : This is a calculated FWHM value.

FWTM : This is a calculated FWTM value.

Xscale : Select the unit of X-axis.

CH : Unit: ch

ns : Unit: ns

---



---

## 5. File

---

### 5. 1. Histogram Data File

---

## (1) File format

Tab-delimited text format

## (2) File name

Arbitrary file name

## (3) Structure

“Header” and “Calculation” and “Status” and “Data”.

## • Header parts

This parts save every CH as follow.

Measurement Mode : Measurement Mode  
 Measurement Time : Measurement Time (Unit: sec)  
 Real Time : Real Time  
 Start Time : Measurement Start Time  
 End Time : Measurement End Time  
 ※Be saved each CH.  
 POL : Polarity  
 TGE : Waveform display trigger CH  
 TGC : Waveform trigger polarity  
 RJT : Waveform getting threshold  
 CCF : CFD Function  
 CDL : CFD Delay  
 CWK : CFD Walk  
 CTH : CFD Threshold  
 FLK : Baseline Time Constant  
 PTS : QDC Pretrigger  
 LIG : QDC Filter Time Constant  
 LIT : QDC Sum or Peak  
 AFS : QDC Integral reduction  
 CLD : QDC LLD  
 CUD : QDC ULD  
 TTY : Timing Type

Only once is saved as follow.

MOD : Mode  
 MTM : Measurement Time  
 MEMO : Memo

---

- Calculation Parts

This parts save every ROI. They are the calculated value between ROI. They saved only devicd in the display.

ROI_Ch	: Set CH.
ROI_Start	: ROI Start position CH
ROI_End	: ROI End position CH
Energy (keV)	: ROI energy(keV)
Peak (ch)	: Peak CH at calculated (ch)
Centroid (ch)	: Centroid CH at calculated (ch)
Peak (count)	: Peak counts at calculated
Gross (count)	: Gross sum counts at calculated.
Gross (cps)	: Gross cps at calculated.
Net (count)	: Sum counts that attracted a background.
Net (cps)	: Csp that attracted a background.
FWHM (ch)	: Full width at half maximum (ch)
FWHM (%)	: Energy resoration of full width at half maximum(%)
FWHM (keV)	: Energy value of Full width at half maximum (keV)
FWTM (keV)	: Energy resoration of full width at tenth maximum (keV)

- Status Parts

※This parts save every CH

Input Total Count	: Total Counts
Throughput Count	: Throughput Counts
Input Total Rate	: Total Count Rate
Throughput Rate	: Throughput Count Rate
Dead Time	: Dead Time Ratio

- Data Parts

Histogram data of each CH. Maximamu: 8192 points

## 5. 2. Wave Data File

---

### (1) File Format

Tab Separated Values Type

### (2) File Name

Arbitrarily Name

### (3) Structure

“Header” and “Calculation” and “Status” and “Data”.

#### • Header Parts

Measurement Mode : Measurement Mode  
 Measurement Time : Measurement Time (Unit: sec)  
 Real Time : Real Time  
 Start Time : Measurement Start Time  
 End Time : Measurement End Time

※Be saved each CH.

POL : Polarity  
 TGE : Waveform display trigger CH  
 TGC : Waveform trigger polarity  
 RJT : Waveform getting threshold  
 CCF : CFD Function  
 CDL : CFD Delay  
 CWK : CFD Walk  
 CTH : CFD Threshold  
 FLK : Baseline Time constant  
 PTS : QDC Pretrigger  
 LIG : QDC Filter Time Constat  
 LIT : QDC Sum or Peak  
 AFS : QDC Integral reduction  
 CLD : QDC LLD  
 CUD : QDC ULD  
 TTY : Timing Type

Only once is saved as follow.

MOD : Mode  
 MTM : Measurement Time  
 MEMO : Memo

#### • Status Parts

※This parts save every CH

Output Count : Output Counts  
 Output Rate : Output Rate  
 Dead Time : Dead Time Ratio

#### • Data Parts

Waveform data of each CH.



## 5. 3. List Data File

### (1) File Format

Binary File, Big Endian File

### (2) Structure

80Bit (10Byte, 5WORD) / event

Bit79		TDC[55..40]		64
63		TDC[39..24]		48
47		TDC[23..8]		32
31	TDC[7..0]		TDCFP[7..0]	16
15	13	12	QDC [12..0]	0
CH[2..0]				

Fig. 5-3-1 List Data (80 Bit)

- Bit79 to Bit24            TDC counts. 56Bit  
In case of APV8508; 1Bit = 2ns  
In case of APV8104; 1Bit = 1ns
  
- Bit23 to Bit16            TDCFP counts. 8Bit  
In the case of APV8508; 1Bit = 7.8125ps  
It is the calculated value of between 2ns.  
 $2\text{ns} / 256 = 7.8125\text{ ps}$   
  
In the case of APV8104; 1Bit = 3.90625ps  
It is the calculated value of between 1ns.  
 $1\text{ns} / 256 = 3.90625\text{ ps}$
  
- Bit15 to Bit13            CH<sub>0</sub> 3Bit  
0:CH1, 1:CH2, 2:CH3, 3:CH4.
  
- Bit12 to Bit0            This is the integral valud of QDC. 13Bit.

### (3) When you use plural boards, and saved.

Format is Header(IP) + Listdata + Header(IP) + Listdata... List data saved to a one file.

Example,

IP is 「192.168.10.128」 and 「192.168.10.129」. Read Event Num set 100. The list data are saved as follows.

Header Parts (192.168.10.128) 0x3139322E3136382E31302E313238	List Parts (1000Byte)	Header Parts (192.168.10.129) 0x3139322E3136382E31302E313239	List Parts (1000Byte)	....
---	--------------------------	---	--------------------------	------

**You can save the list data without a header, too.**

**In this case, please set OFF header in the 'file' TAB of application.**

---

## 5. 4. List-Wave Data File

---

### (1) File Format

Binary File, Big Endian File

### (2) Structure

It is 10 Byte List data and CH Header and Wave data according to list wave length. For example, if wave length seted 100point(100ns), Data byte number is 214 bytes (10-byte list data and 4-byte Header and 200-Byte wave data). The 1-point wave data is 2-byte. Header used ASCII-code, CH1 header is WAV0 (= 0x57415630), CH2 header is WAV1 (= 0x57415631), CH3 header is WAV2 (= 0x57415632) and CH4 header is WAV3 (= 0x57415633).

For example when wave data length is 100point and signal detected on CH3.

List data (10Byte)	Header Parts (4Byte) 0x57415632	Wave data (200Byte)
-----------------------	---------------------------------------	------------------------

## 6. Command

### 6. 1. General Outline

Setting or getting data depend on TCP/IP or UDP via the ethernet.

Special library is not used. Special library is not used. If you are based on a communication format (command), you can control DPP by any application.

A board for communication is put on DPP.

Board for communication	Communication standard	Communication Protocol	Command method
APG5107	1000Mbps	TCP/IP or UDP	Address + parameter

This chapter lists it about a command when you are putting APG5107 on a board for communication.

APG5107 is adopting SiTCP to realize high-speed data communication. SiTCP is a technique to connect an apparatus developed in university combination use engine corporation High Energy Accelerator Research Organization (<http://www.kek.jp/ja/>, following KEK) to ethernet and is transferred the skill to Bee Beans Technologies (<http://www.bbtech.co.jp>, following BBT) which is from KEK venture company Co., Ltd. now. When you use SiTCP, be receiving licensing from BBT. Please refer to each manual of the BBT company website for the details of the transmission and reception of SiTCP and data.

The kind of the command is classified roughly into "Config (setting) and Status (Status)", two of "Data (data)". Two protocols of TCP/IP and the UDP are working to transmit and receive these two kinds of commands in SiTCP without competing, and be defining the communication port of the equipment side in each. Config and Status are UDP, and the port number is by default the 4660th. Data is TCP/IP, and the port number is by default the 24th.

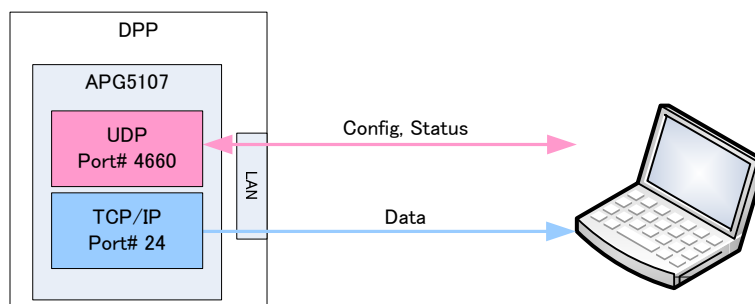

List below it about a format and the kind of the command.

## 6. 2. Command Format

---

In the case of Config note, in the case of Status reading, the format of the command may include Data reading. Be comprised of "header part" and "address part" and "parameter part" and department of "data".

Six items of Ver/Type/CMD/FLAG/ID/Data Length in conformity with specifications of SiTCP are included in "header part". Data Length (the data head) is fixed 2Byte, and, in DPP, the size of the header part becomes 4Byte.

"Address part" is an address of 4Byte of the register in DPP.

"Parameter part" is a value of 2Byte to set to a register in DPP.

Department of "data" is measurement data from DPP.

## 6. 3. Command Type

### (1) Config command

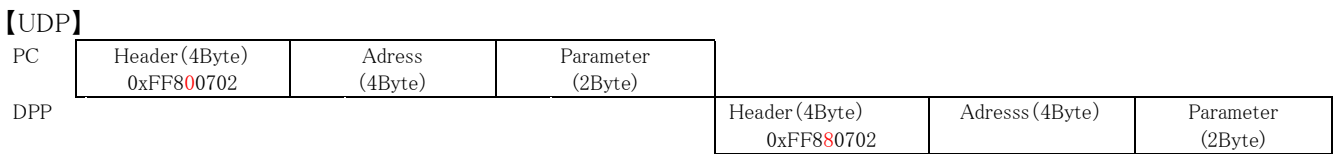

Fig. 6-3-1 In the case of Config Comannd

We have a reply for the Config command for the setting from a PC from DPP.

#### 【Setteing from a PC】

"Header part" is "FF800702" by 4Byte, a hex digit. Contents are F (Ver.) F(Type)8(CMD)0(FLG)07(ID)02(Data Length).

"Address part" sets 4Byte, an address level of the parameter.

"Parameter part" is 2Byte, a parameter level to set.

#### 【Reply from DPP】

"Header part" is "FF880702" by 4Byte, a hex digit. Contents are F (Ver.) F(Type)8(CMD)8(FLG)07(ID)02(Data Length). ACK bit of FLG becomes 1 if normal, and become 8.

An address level of the parameter that "address part" is 4Byte and set returns.

There is not "parameter part", and the value that you set does not come back.

## (2) Status Command

## 【UDP】

PC	Header(4Byte) 0xFFC00602	Adress(4Byte)			
DPP			Header(4Byte) 0xFFC80602	Adress(4Byte)	Date(2Byte)

Fig. 6-3-2 In the case of Status Comannnd

We have a reply for the Status command for the demand from a PC from DPP.

## 【Demand from a PC】

"Header part" is "FFC00602" by 4Byte, a hex digit. Contents are F (Ver.) F(Type)C(CMD)0(FLG)06(ID)02(Data Length).

"Address part" sets 4Byte, an address level of status data.

## 【Reply from DPP】

"Header part" is 4Byte, and be "FFC80602" with a hexadecimal. Contents are F (Ver.)

F(Type)C(CMD)8(FLG)06(ID)02(Data Length). ACK bit of FLG becomes 1 if normal, and become 8.

4Byte, an address level of the parameter that you required return to "address part".

Department of "data" is 2Byte, a status data level.

**(3) Data Command**

A PC can read list data by Data command. At first require list data by UDP, and there is a reply of the department of data by TCP/IP from DPP.

**【TCP/IPDPP down-link】**

List data begin to collect to the board for communication when they let they set a list mode by UDP and start.

**【The TCP/IPPC data reception】**

Hold it for any byte in TCP, and can perform reading. The list data, please perform the reading by the 10byte unit for 10byte unit.

## 6. 4. Command Table

No.	Type	Port No.	HEX Address	Contents	Setting range (digit)	Motion	Command length (Byte)	Reply (Byte)
1	CH Setting	UDP 4660	B40001DE	Input Waveform Type	0, 2	Setting	10	8
						Request of setting	8	10
2			B400011A	Input Polar Character Switch	0, 1	Setting	10	8
						Request of setting	8	10
3			B4000160	CFD Function	1..15	Setting	10	8
						Request of setting	8	10
4			B4000162	CFD Delay	0..23	Setting	10	8
						Request of setting	8	10
5			B4000164	CFD Walk	0.. $2^{10}-1$	Setting	10	8
						Request of setting	8	10
6			B4000166	Threshold	0.. $2^{13}-1$	Setting	10	8
						Request of setting	8	10
7			B400016E	Baseline Restorer Filter	0..254	Setting	10	8
						Request of setting	8	10
8			B40001C0	QDC Pretrigger	0..8	Setting	10	8
						Request of setting	8	10
9			B40001C6	QDC Filter	0..5	Setting	10	8
						Request of setting	8	10
10			B40001C8	QDC sum/peak	0, 1	Setting	10	8
						Request of setting	8	10
11	B400010C	QDC Full Scale	0..9	Setting	10	8		
				Request of setting	8	10		
12	B40001DC	QDC Integral Range	0.. $2^{12}-1$	Setting	10	8		
				Request of setting	8	10		
13	B4000168	QDC LLD	0.. $2^{13}-1$	Setting	10	8		
				Request of setting	8	10		
14	B400016A	QDC ULD	0.. $2^{13}-1$	Setting	10	8		
				Request of setting	8	10		
15	B400010E	Analog Gain	0, 1	Setting	10	8		
				Request of setting	8	10		
16	B4000170	Analog Offset	0.. $2^{12}-1$	Setting	10	8		
				Request of setting	8	10		
17	B40001D0	Time Stamp Timing	0, 1	Setting	10	8		
				Request of setting	8	10		
18	B4000174	List wave delay	0..30	Setting	10	8		
				Request of setting	8	10		
19	B400017A	List wave data	4..511	Setting	10	8		
				Request of setting	8	10		
20	B4000180	OR enable	0, 1	Setting	10	8		
				Request of setting	8	10		

※The above-mentioned address is CH1. The head address of CH1 is B4000100. The head address of CH2 is B4000200. Therefore the address of adding 0x100 is the head of each CH setting.



No.	Type	Port No.	HEX Address	Contents	Setting range (digit)	Motion	Command length (Byte)	Reply (Byte)
21	Single Setting	UDP 4660	B4000000	Mode	0, 1, 2	Setting	10	8
22						Request of setting	8	10
23			B4000002	Measurement Mode	0, 1	Setting	10*4 times	8*4 times
						Request of setting	8*4 times	10*4 times
24			B4000004	Measurement Start	0, 1	Setting	10	8
						Request of setting	8	10
25			B4000090	Data Clear	0, 1	Setting	10	8
26			B4000070	OR length	0..125	Setting	10	8
27	B400004A	Write wait num	0..5	Setting	10	8		
28	Stetas	UDP 4660	B4000004	Measurement State	-	Request of stetas	10	8
29			B4000120 B4000122 ※	Outout Count Total			10*2 times	8*2times
30			B4000130 B4000132 ※	Output Count Rate			10*2 times	8*2 times
31			B40001E0 B40001E2 B40001E4 B40001E6 ※	Dead Count			10*4 times	8*4 times
32			B400000E B4000010 B4000012 B4000014	Real Time			10*4 times	8*4 times
33			B400009A	Histogram CH Data			10	32768

※The ※ mark of the above-mentioned address is CH1. A value of each CH setting is an address to add 0x100.

---

## 6. 5. Description

---

### CH Setting

#### 1. Input Waveform Type Selection

Comment : Select the type of input waveform  
Address : 0xB40001DE  
Setting : Command length 10Byte, Reply 8Byte  
Request : Command length 8Byte, Reply 10Byte  
Port No. : 4660 (UDP)  
Type : Channel setting  
Range : 0 or 1  
0: Normal waveform  
1: NIM waveform

#### 2. Input Polar Character Switch

Comment : Select the polar character of input signal  
Address : 0xB400011A  
Setting : Command length 10Byte, Reply 8Byte  
Request : Command length 8Byte, Reply 10Byte  
Port No. : 4660 (UDP)  
Type : Channel setting  
Range : 0 or 1  
0: Negative  
1: Positive

#### 3. CFD Function

Comment : Setting of CFD function. The signal reduction ratio which to use the CFD waveform calculation.  
Address : 0xB4000160  
Setting : Command length 10Byte, Reply 8Byte  
Request : Command length 8Byte, Reply 10Byte  
Port No. : 4660 (UDP)  
Type : Channel setting  
Range : 1 to 15  
1: 0.03 x  
2: 0.06 x  
3: 0.09 x  
4: 0.12 x  
5: 0.15 x  
6: 0.18 x  
7: 0.21 x  
8: 0.25 x  
9: 0.28 x  
10: 0.31 x  
11: 0.34 x  
12: 0.37 x  
13: 0.40 x  
14: 0.43 x  
15: 0.46 x

## 4. CFD Delay

Comment : Setting of CFD delay. The delay time of the reversed signal which to use the CFD waveform calculation.

Address : 0xB4000162

Setting : Command length 10Byte, Reply 8Byte

Request : Command length 8Byte, Reply 10Byte

Port No. : 4660 (UDP)

Type : Channel setting

Range : 0 to 23

0: 1ns	8 : 9ns	16 : 17ns
1: 2ns	9 : 10ns	17 : 18ns
2: 3ns	10 : 11ns	18 : 19ns
3: 4ns	11 : 12ns	19 : 20ns
4: 5ns	12 : 13ns	20 : 21ns
5: 6ns	13 : 14ns	21 : 22ns
6: 7ns	14 : 15ns	22 : 23ns
7: 8ns	15 : 16ns	23 : 24ns

## 5. CFD Walk

Comment : Time stamp setting for ADC data

Address : 0xB4000164

Setting : Command length 10Byte, Reply 8Byte

Request : Command length 8Byte, Reply 10Byte

Port No. : 4660 (UDP)

Type : Channel setting

Range : 0 to 1023

## 6. Threshold

Comment : Threshold setting of the input waveform

Address : 0xB4000166

Setting : Command length 10Byte, Reply 8Byte

Request : Command length 8Byte, Reply 10Byte

Port No. : 4660 (UDP)

Type : Channel setting

Range : 0 to 8191

## 7. Baseline Restorer Filter

Comment : Filter time constant of baseline restorer filter

Address : 0xB400016E

Setting : Command length 10Byte, Reply 8Byte

Request : Command length 8Byte, Reply 10Byte

Port No. : 4660 (UDP)

Type : Channel setting

Range : 0 to 4

0 : off

64 : fast

128 : 4 $\mu$ s

250 : 85 $\mu$ s

252 : 129  $\mu$ s

254 : 260  $\mu$ s

---

## 8. QDCPretrigger

Comment : Set a timing to start the addition  
Address : 0xB40001C0  
Setting : Command length 10Byte, Reply 8Byte  
Request : Command length 8Byte, Reply 10Byte  
Port No. : 4660 (UDP)  
Type : Channel setting  
Range : 0 to 8

0: 0ns	5: Before 40ns of the timing of threshold.
1: Before 8ns of the timing of threshold.	6: Before 48ns of the timing of threshold.
2: Before 16ns of the timing of threshold.	7: Before 56ns of the timing of threshold.
3: Before 24ns of the timing of threshold.	8: Before 64ns of the timing of threshold.
4: Before 32ns of the timing of threshold.	

## 9. QDC Filter

Comment : Filter time constant of original waveform which QDC integrates.  
Address : 0xB40001C6  
Setting : Command length 10Byte, Reply 8Byte  
Request : Command length 8Byte, Reply 10Byte  
Port No. : 4660 (UDP)  
Type : Channel setting  
Range : 0 to 5

0: non-filter
1: 10ns
2: 20ns
3: 50ns
4: 100 ns
5: 200 ns

## 10. QDC sum/peak

Comment : Type of output data of QDC.  
Address : 0xB40001C8  
Setting : Command length 10Byte, Reply 8Byte  
Request : Command length 8Byte, Reply 10Byte  
Port No. : 4660 (UDP)  
Type : Channel setting  
Range : 0 or 1

0: peak	Output a peak value of the waveform as QDC data
1: sum	Output an integral value of the filtered waveform as QDC data

---

## 11. QDC Full Scale

Comment : Gain of QDC data  
Address : 0xB400010C  
Setting : Command length 10Byte, Reply 8Byte  
Request : Command length 8Byte, Reply 10Byte  
Port No. : 4660 (UDP)  
Type : Channel setting  
Range : 0 to 8  
0: 1/1 x  
1: 1/2 x  
2: 1/4 x  
3: 1/8 x  
4: 1/16 x  
5: 1/32 x  
6: 1/64 x  
7: 1/128 x  
8: 1/256 x  
8: 1/512 x

## 12. QDC Integral Range

Comment : The setting of the integral time included the setting time of QDC pretrigger.  
Address : 0xB40001DC  
Setting : Command length 10Byte, Reply 8Byte  
Request : Command length 8Byte, Reply 10Byte  
Port No. : 4660 (UDP)  
Type : Channel setting  
Range : 0 to 4095 (1digit = 8ns, 4095 = 32768ns)

## 13. QDC LLD

Comment : LLD of the value of integral of QDC.  
Address : 0xB4000168  
Setting : Command length 10Byte, Reply 8Byte  
Request : Command length 8Byte, Reply 10Byte  
Port No. : 4660 (UDP)  
Type : Channel setting  
Range : 0 to 8191

## 14. QDC ULD

Comment : ULD of the value of integral of QDC.  
Address : 0xB400016A  
Setting : Command length 10Byte, Reply 8Byte  
Request : Command length 8Byte, Reply 10Byte  
Port No. : 4660 (UDP)  
Type : Channel setting  
Range : 0 to 8191

---

## 15. Analog Gain

Comment : Gain of analog circuit  
Address : 0xB400010E  
Setting : Command length 10Byte, Reply 8Byte  
Request : Command length 8Byte, Reply 10Byte  
Port No. : 4660 (UDP)  
Type : Channel setting  
Range : 0 or 1  
0: 3 x  
1: 1 x

## 16. Analog Offset

Comment : Offset adjustment of analog circuit  
Address : 0xB4000170  
Setting : Command length 10Byte, Reply 8Byte  
Request : Command length 8Byte, Reply 10Byte  
Port No. : 4660 (UDP)  
Type : Channel setting  
Range : 0 to 4095  
0: +1000mV ※Default; 2047  
~  
4095: -1000mV

## 17. Time Stamp Timing

Comment : When the time stamp of the time information, which do you choose the timing of waveform?  
Address : 0xB40001D0  
Setting : Command length 10Byte, Reply 8Byte  
Request : Command length 8Byte, Reply 10Byte  
Port No. : 4660 (UDP)  
Type : Single setting  
Range : 0 or 1  
0: The timing is the setting in CFDWALK for CFD waveform.  
1: The timing is the setting reading edge in CFDWALK for original waveform.

## 18. List Wave Delay

Comment : You can set the wave position into List wave data when you select list-wave mode.  
Address : 0xB4000174  
Setting : Command length 10Byte, Reply 8Byte  
Request : Command length 8Byte, Reply 10Byte  
Port No. : 4660 (UDP)  
Type : Single setting  
Range : 0 to 30. Default it is set '8'.

## 19. List Wave Date

Comment : You can set wave data length.  
Address : 0xB400017A  
Setting : Command length 10Byte, Reply 8Byte  
Request : Command length 8Byte, Reply 10Byte  
Port No. : 4660 (UDP)  
Type : Single setting  
Range : 4 to 511. 1digit is 8ns (8point).

## 20. OR Enable

Comment : You can select OR function every CH.  
Address : 0xB4000180  
Setting : Command length 10Byte, Reply 8Byte  
Request : Command length 8Byte, Reply 10Byte  
Port No. : 4660 (UDP)  
Type : Single setting  
Range : 0, 1. '0' is disenable, '1' is enable.

## Single setting

## 21. Mode

Comment : Operation mode. Select of Hist (Histogram) mode, Wave (Waveform) mode, List (List) mode.  
 Address : 0xB4000000  
 Setting : Command length 10Byte, Reply 8Byte  
 Request : Command length 8Byte, Reply 10Byte  
 Port No. : 4660 (UDP)  
 Type : Single setting  
 Range : 0 to 2  
         0: Hist Mode  
         1: Wave Mode  
         2: List Mode (Optional setting)

## 22. Measurement Mode

Comment : Select of Real Time or Live Time  
 Address : 0xB4000002  
 Setting : Command length 10Byte, Reply 8Byte  
 Request : Command length 8Byte, Reply 10Byte  
 Port No. : 4660 (UDP)  
 Type : Single setting  
 Range : 0 to 1  
         0: Real Time  
         1: Live Time

## 23. Measurement Time

Comment : Measurement time  
 Address : 0xB4000006 (MSB), 0xB4000008, 0xB400000A (LSB)  
 Setting : Command length 10Byte, Reply 8Byte  
 Request : Command length 8Byte, Reply 10Byte  
 Port No. : 4660 (UDP)  
 Type : Single setting  
 Range : 0 to  $2^{54}-1$  digit  
         1digit is 8ns. Maximum setting is 8760 hours..

## 24. Measurement Start

Comment : Select of measurement start or stop  
 Address : 0xB4000004  
 Setting : Command length 10Byte, Reply 8Byte  
 Request : Command length 8Byte, Reply 10Byte  
 Port No. : 4660 (UDP)  
 Type : Single setting  
 Range : 0 or 1  
         0: Measurement Stop  
         1: Measurement Start

## 25. Data Clear

Comment : Data Clear  
 Address : 0xB4000090  
 Setting : Command length 10Byte, Reply 8Byte  
 Request : Command length 8Byte, Reply 10Byte  
 Port No. : 4660 (UDP)  
 Type : Single setting  
 Range : If you want to clear the data, please set data consecutively with 0→1→0.



## 26. OR Length

Comment : Setable length of TTL signal  
Address : 0xB4000070  
Setting : Command length 10Byte, Reply 8Byte  
Request : Command length 8Byte, Reply 10Byte  
Port No. : 4660 (UDP)  
Type : Single setting  
Range : 5 to 125. 1digit is 8ns.

## 27. Write wait num

Comment : You can adjust the transferspeed of list data and list wave data. Whether correct data can accquier from module, depend on pc spec or firmware or etc.

Address : 0xB4000070  
Setting : Command length 10Byte, Reply 8Byte  
Request : Command length 8Byte, Reply 10Byte  
Port No. : 4660 (UDP)  
Type : Single setting  
Range : 0 to 5. Default set '4'.

Relashinship between transfer speed and writ wait num show below.

0 : 67 Mbyte/s  
1 : 54 Mbyte/s  
2 : 45 Mbyte/s  
3 : 38 Mbyte/s  
4 : 33 Mbyte/s  
5 : 28 Mbyte/s

---

Status

28. Measurement State

Comment : This is to confirm the setting.  
Address : 0xB4000004  
Request : Command length 8Byte, Reply 10Byte  
Port No. : 4660 (UDP)  
Type : Status  
State : 0 or 1  
0: During a measurement stop  
1: During a measurement

29. Throughput Count Total

Comment : Signal processed total number of counts within QDCLLD and QDCULD.  
Address : 0xB4000120 (MSB), 0xB4000122 (LSB)  
Request : Command length 8Byte, Reply 10Byte  
Port No. : 4660 (UDP)  
Type : Status (CH)  
State :

30. Throughput Count Rate

Comment : Throughput count total / sec  
Address : 0xB4000130 (MSB), 0xB4000132 (LSB)  
Request : Command length 8Byte, Reply 10Byte  
Port No. : 4660 (UDP)  
Type : Status (CH)  
State :

---

### 31. Dead Count

Comment : Total Dead Counts  
Address : 0xB40001E0 (MSB)、0xB40001E2、0xB40001E4、0xB40001E6 (LSB)  
Request : Command length 8Byte, Reply 10Byte  
Port No. : 4660 (UDP)  
Type : Status (CH)  
State :

### 32. Real Time

Comment : Real Time (8ns/Count)  
Address : 0xB40001E0 (MSB)、0xB40001E2、0xB40001E4、0xB40001E6 (LSB)  
Request : Command length 8Byte, Reply 10Byte  
Port No. : 4660 (UDP)  
Type : Status  
State :

### 33. Histogram CH Data

Comment : Request of histogram data  
Address : 0xB400009A  
Setting : Command length 10Byte, Reply 32768Byte  
Port No. : 4660 (UDP)  
Type : Setting  
State :

- 0: Request of CH1 histogram
- 1: Request of CH2 histogram
- 2: Request of CH3 histogram
- 3: Request of CH4 histogram

※For Example:

If you want to acquire histogram data of CH0, there is data reply of histogram data (32768 byte) of CH0 by UDP when you set data (0x0000) in address (0xB400009A).

## 6. 6. Command transmission and reception example

List below an example of configuration, clear, start, hist, list, wave. The port number of the PC side to use in UDP socket is arbitrary. The port number to use in UDP send to the APV8508 or APV8104 side is 4660. The port number to use in TCP/IP socket is 24. The byte order of the command is big endian (MSB First).

※In case of APV8104, exchange APV8508 to APV8104.

(1) configuration

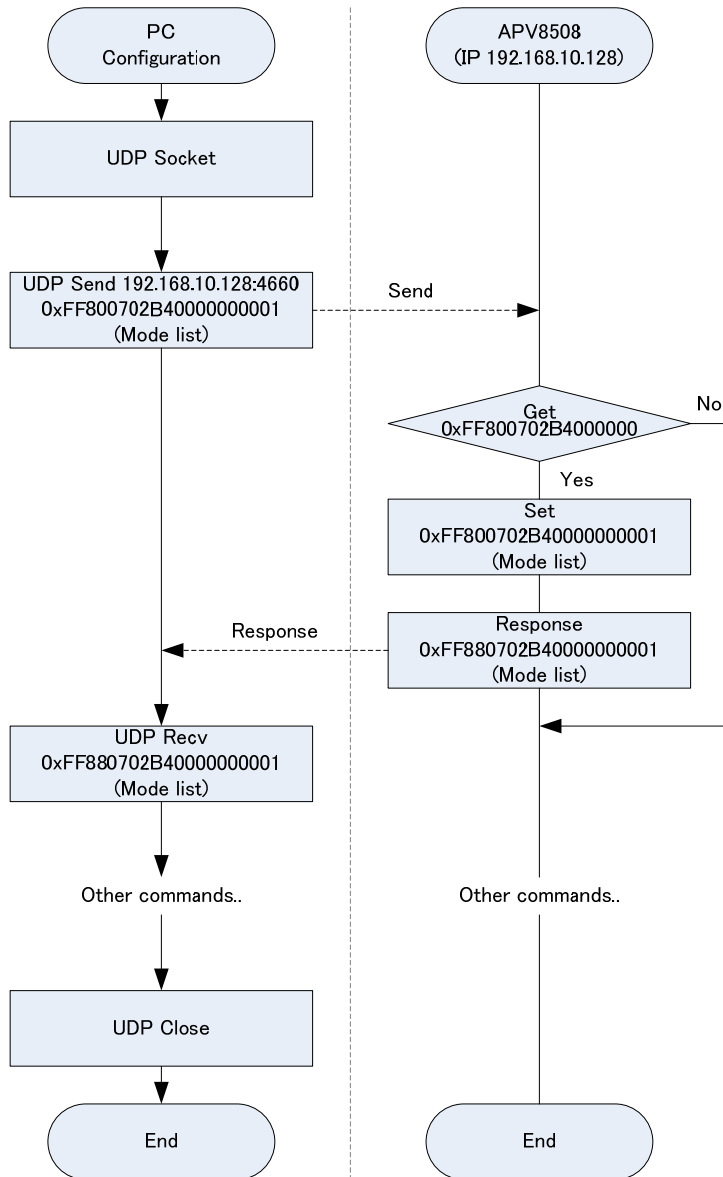

※List Config practice procedure from the following page.

```

//
// Exsample about Commands of Configuration
//

UDP socket

//MODE
UDP send 0xFF800702B4000000001
UDP rcv  0xFF880702B4000000001

// Measurement Time Setting
UDP send 0xFF800702B4000060000
UDP rcv  0xFF880702B4000060000
UDP send 0xFF800702B4000080068
UDP rcv  0xFF880702B4000080068
UDP send 0xFF800702B40000AC617
UDP rcv  0xFF880702B40000AC617
UDP send 0xFF800702B40000C1400
UDP rcv  0xFF880702B40000C1400

// polarity
UDP send 0xFF800702B400011A0000
UDP rcv  0xFF880702B400011A0000
UDP send 0xFF800702B400021A0000
UDP rcv  0xFF880702B400021A0000
UDP send 0xFF800702B400031A0000
UDP rcv  0xFF880702B400031A0000
UDP send 0xFF800702B400041A0000
UDP rcv  0xFF880702B400041A0000

// QDC full scale (multiple)
UDP send 0xFF800702B400010C0001
UDP rcv  0xFF880702B400010C0001
UDP send 0xFF800702B400020C0001
UDP rcv  0xFF880702B400020C0001
UDP send 0xFF800702B400030C0001
UDP rcv  0xFF880702B400030C0001
UDP send 0xFF800702B400040C0001
UDP rcv  0xFF880702B400040C0001

// CFD function (multiple)
UDP send 0xFF800702B40001600007
UDP rcv  0xFF880702B40001600007
UDP send 0xFF800702B40002600007
UDP rcv  0xFF880702B40002600007
UDP send 0xFF800702B40003600007
UDP rcv  0xFF880702B40003600007
UDP send 0xFF800702B40004600007
UDP rcv  0xFF880702B40004600007

// CFD delay
UDP send 0xFF800702B40001620004
UDP rcv  0xFF880702B40001620004
UDP send 0xFF800702B40002620004
UDP rcv  0xFF880702B40002620004
UDP send 0xFF800702B40003620004
UDP rcv  0xFF880702B40003620004
UDP send 0xFF800702B40004620004
UDP rcv  0xFF880702B40004620004

UDP send 0xFF800702B40004620004
UDP rcv  0xFF880702B40004620004

// CFD walk
UDP send 0xFF800702B4000164000A
UDP rcv  0xFF880702B4000164000A
UDP send 0xFF800702B4000264000A
UDP rcv  0xFF880702B4000264000A
UDP send 0xFF800702B4000364000A
UDP rcv  0xFF880702B4000364000A
UDP send 0xFF800702B4000464000A
UDP rcv  0xFF880702B4000464000A

// threshold
UDP send 0xFF800702B40001660014
UDP rcv  0xFF880702B40001660014
UDP send 0xFF800702B40002660014
UDP rcv  0xFF880702B40002660014
UDP send 0xFF800702B40003660014
UDP rcv  0xFF880702B40003660014
UDP send 0xFF800702B40004660014
UDP rcv  0xFF880702B40004660014

// QDC LLD
UDP send 0xFF800702B40001680014
UDP rcv  0xFF880702B40001680014
UDP send 0xFF800702B40002680014
UDP rcv  0xFF880702B40002680014
UDP send 0xFF800702B40003680014
UDP rcv  0xFF880702B40003680014
UDP send 0xFF800702B40004680014
UDP rcv  0xFF880702B40004680014

// QDC ULD
UDP send 0xFF800702B400016A1FFF
UDP rcv  0xFF880702B400016A1FFF
UDP send 0xFF800702B400026A1FFF
UDP rcv  0xFF880702B400026A1FFF
UDP send 0xFF800702B400036A1FFF
UDP rcv  0xFF880702B400036A1FFF
UDP send 0xFF800702B400046A1FFF
UDP rcv  0xFF880702B400046A1FFF

// baseline restorer filter
UDP send 0xFF800702B400016E00FC
UDP rcv  0xFF880702B400016E00FC
UDP send 0xFF800702B400026E00FC
UDP rcv  0xFF880702B400026E00FC
UDP send 0xFF800702B400036E00FC
UDP rcv  0xFF880702B400036E00FC
UDP send 0xFF800702B400046E00FC
UDP rcv  0xFF880702B400046E00FC
E00FC

// QDC pretrigger
UDP send 0xFF800702B40001C00002
UDP rcv  0xFF880702B40001C00002

```

```

UDP send 0xFF800702B40002C00002
UDP rcv  0xFF880702B40002C00002 // QDC integral range
UDP send 0xFF800702B40003C00002 UDP send 0xFF800702B40001DC0013
UDP rcv  0xFF880702B40003C00002 UDP rcv  0xFF880702B40001DC0013
UDP send 0xFF800702B40004C00002 UDP send 0xFF800702B40002DC0013
UDP rcv  0xFF880702B40004C00002 UDP rcv  0xFF880702B40002DC0013
                                         UDP send 0xFF800702B40003DC0013
                                         UDP rcv  0xFF880702B40003DC0013
                                         UDP send 0xFF800702B40004DC0013
                                         UDP rcv  0xFF880702B40004DC0013

// QDC Filter
UDP send 0xFF800702B40001C60001
UDP rcv  0xFF880702B40001C60001
UDP send 0xFF800702B40002C60001
UDP rcv  0xFF880702B40002C60001
UDP send 0xFF800702B40003C60001
UDP rcv  0xFF880702B40003C60001
UDP send 0xFF800702B40004C60001
UDP rcv  0xFF880702B40004C60001

// QDC sum/peak
UDP send 0xFF800702B40001C80001
UDP rcv  0xFF880702B40001C80001
UDP send 0xFF800702B40002C80001
UDP rcv  0xFF880702B40002C80001
UDP send 0xFF800702B40003C80001
UDP rcv  0xFF880702B40003C80001
UDP send 0xFF800702B40004C80001
UDP rcv  0xFF880702B40004C80001

// analog gain (multiple)
UDP send 0xFF800702B400010E0001
UDP rcv  0xFF880702B400010E0001
UDP send 0xFF800702B400020E0001
UDP rcv  0xFF880702B400020E0001
UDP send 0xFF800702B400030E0001
UDP rcv  0xFF880702B400030E0001
UDP send 0xFF800702B400040E0001
UDP rcv  0xFF880702B400040E0001

// analog offset
UDP send 0xFF800702B40001700800
UDP rcv  0xFF880702B40001700800
UDP send 0xFF800702B40002700800
UDP rcv  0xFF880702B40002700800
UDP send 0xFF800702B40003700800
UDP rcv  0xFF880702B40003700800
UDP send 0xFF800702B40004700800
UDP rcv  0xFF880702B40004700800

//Parameter enable
UDP send 0xFF800702B40001B00001
UDP rcv  0xFF880702B40001B00001
UDP send 0xFF800702B40002B00001
UDP rcv  0xFF880702B40002B00001
UDP send 0xFF800702B40003B00001
UDP rcv  0xFF880702B40003B00001
UDP send 0xFF800702B40004B00001
UDP rcv  0xFF880702B40004B00001

// Signal type
UDP send 0xFF800702B40001DE0000
UDP rcv  0xFF880702B40001DE0000
UDP send 0xFF800702B40002DE0000
UDP rcv  0xFF880702B40002DE0000
UDP send 0xFF800702B40003DE0000
UDP rcv  0xFF880702B40003DE0000
UDP send 0xFF800702B40004DE0000
UDP rcv  0xFF880702B40004DE0000

// Timing Type
UDP send 0xFF800702B40001D00000
UDP rcv  0xFF880702B40001D00000
UDP send 0xFF800702B40002D00000
UDP rcv  0xFF880702B40002D00000
UDP send 0xFF800702B40003D00000
UDP rcv  0xFF880702B40003D00000
UDP send 0xFF800702B40004D00000
UDP rcv  0xFF880702B40004D00000

//Measurement mode
UDP send 0xFF800702B40000020000
UDP rcv  0xFF880702B40000020000

//ACS#1
UDP send 0xFF800702B400002A0000
UDP rcv  0xFF880702B400002A0000

//ACS#2
UDP send 0xFF800702B400002A0001
UDP rcv  0xFF880702B400002A0001

//ACS#3
UDP send 0xFF800702B400002A0000
UDP rcv  0xFF880702B400002A0000

UDP Close

```

(2) clear

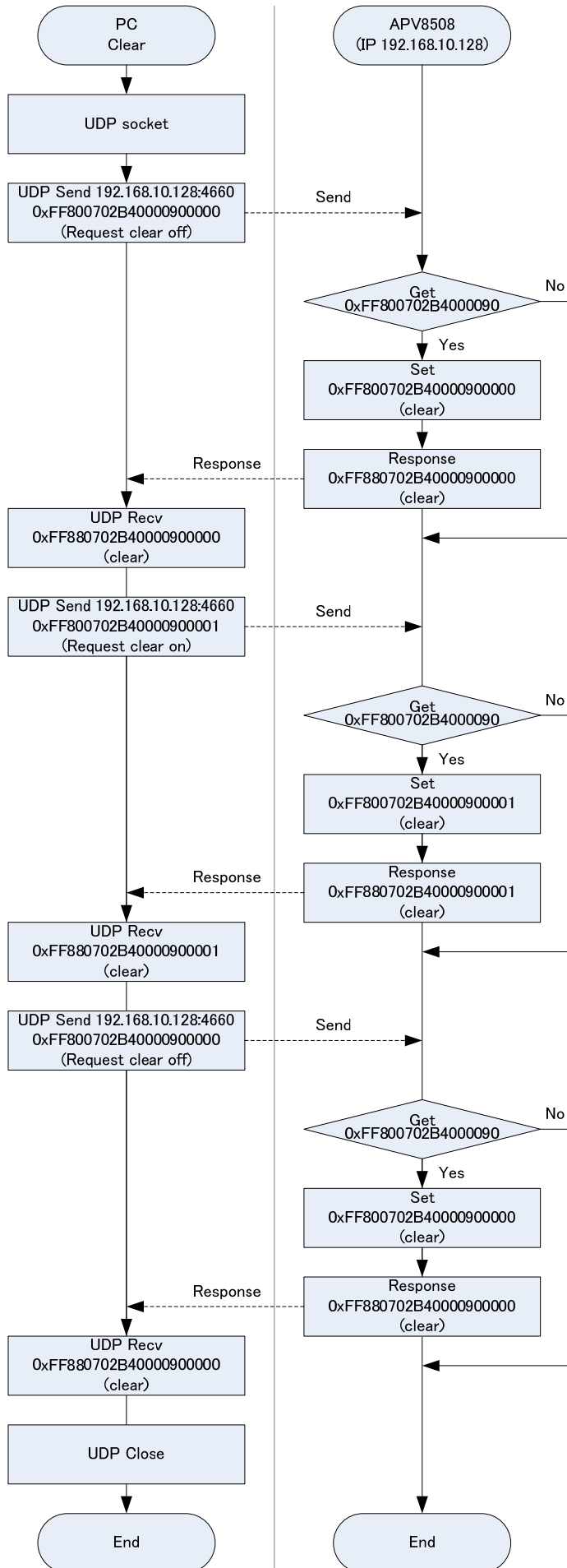

(3) start

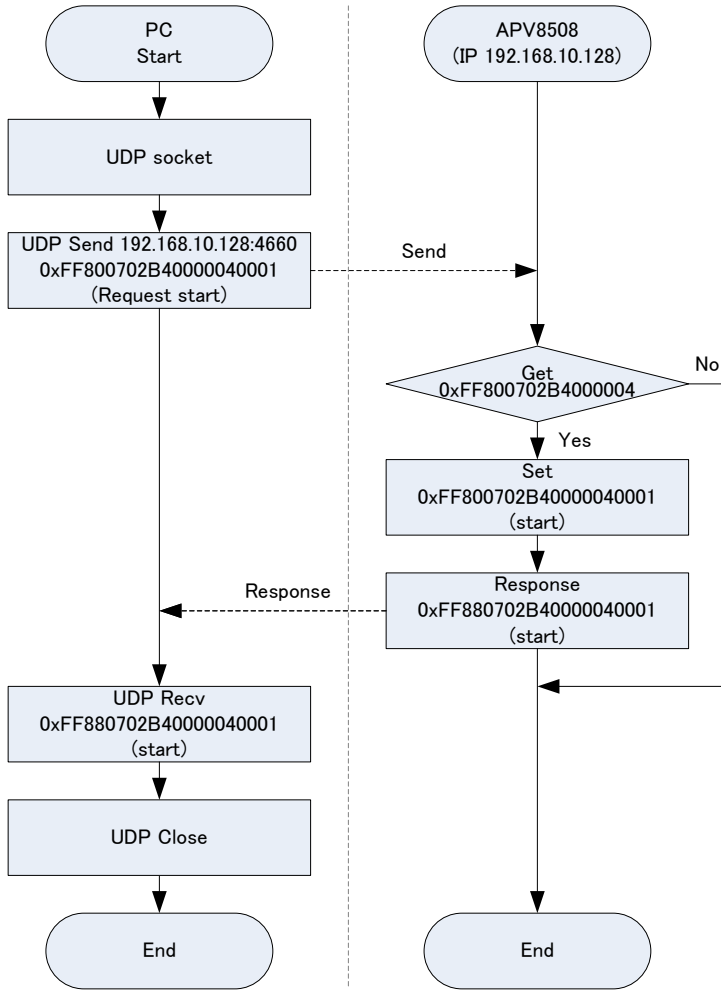



(4) stop

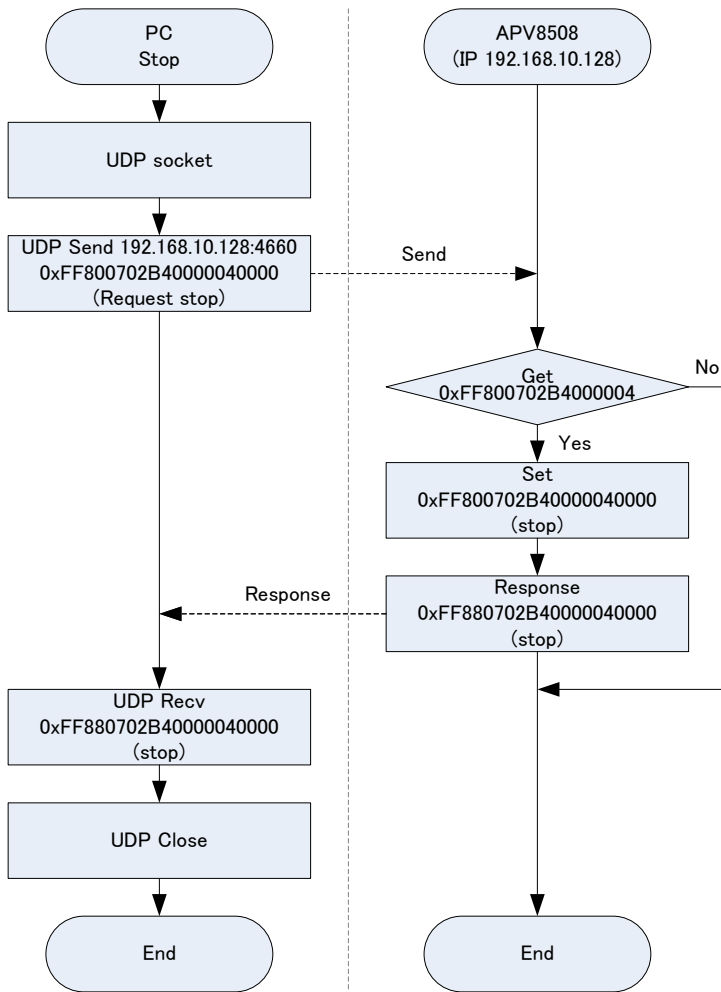

(5) hist

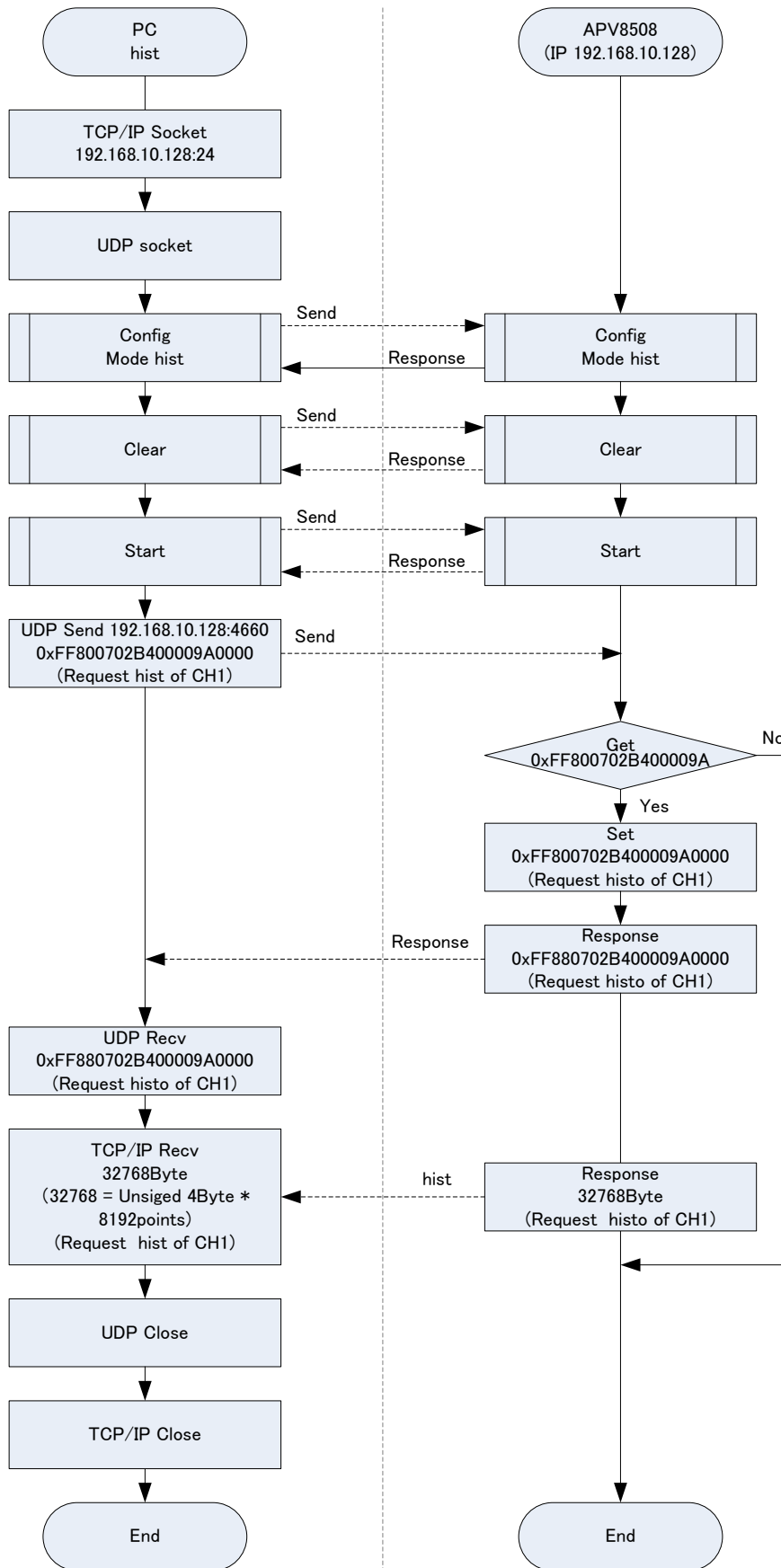

(6) wave data

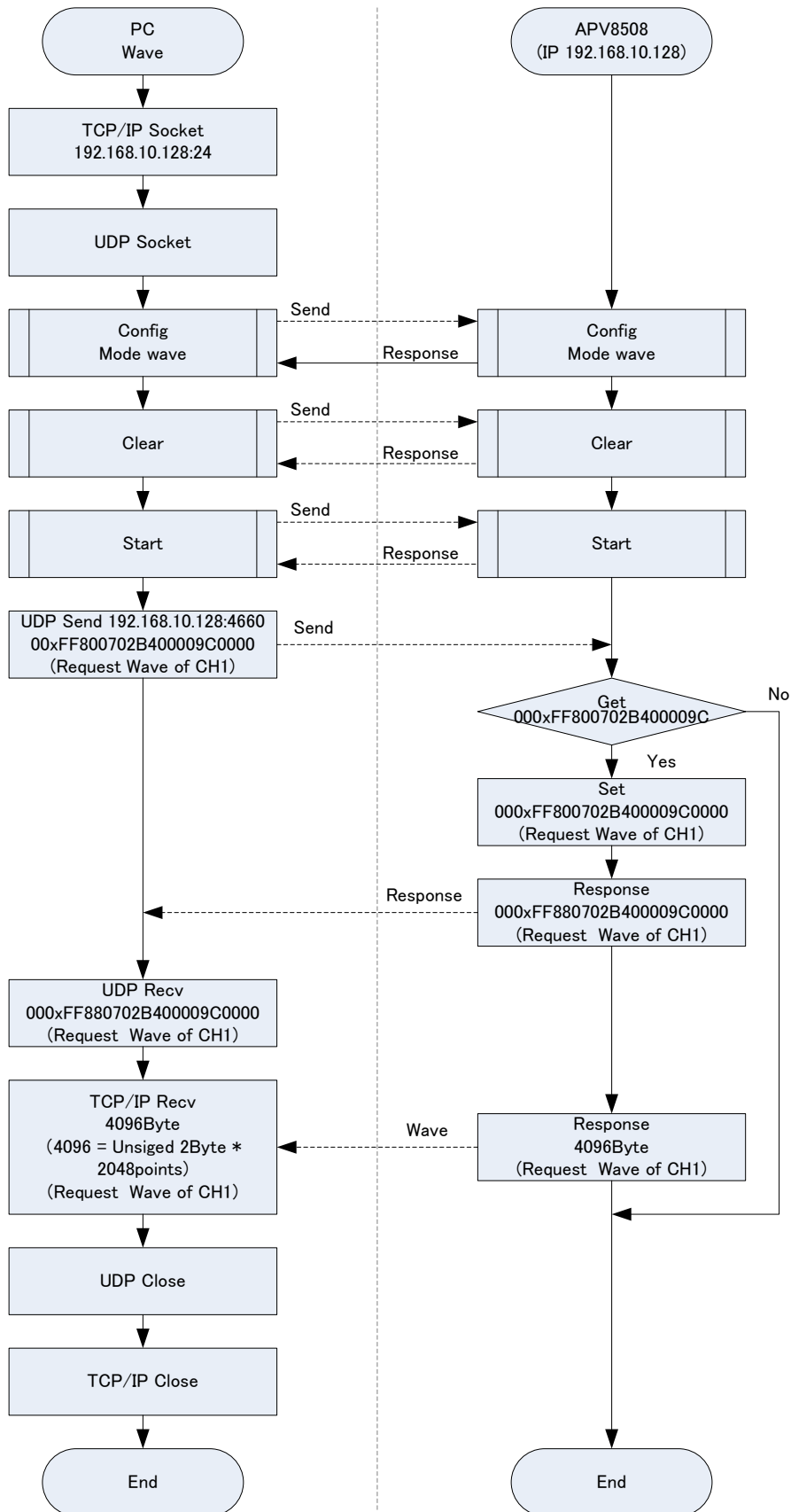

(7) list mode and list-wave mode. You change only set mode(Red box).

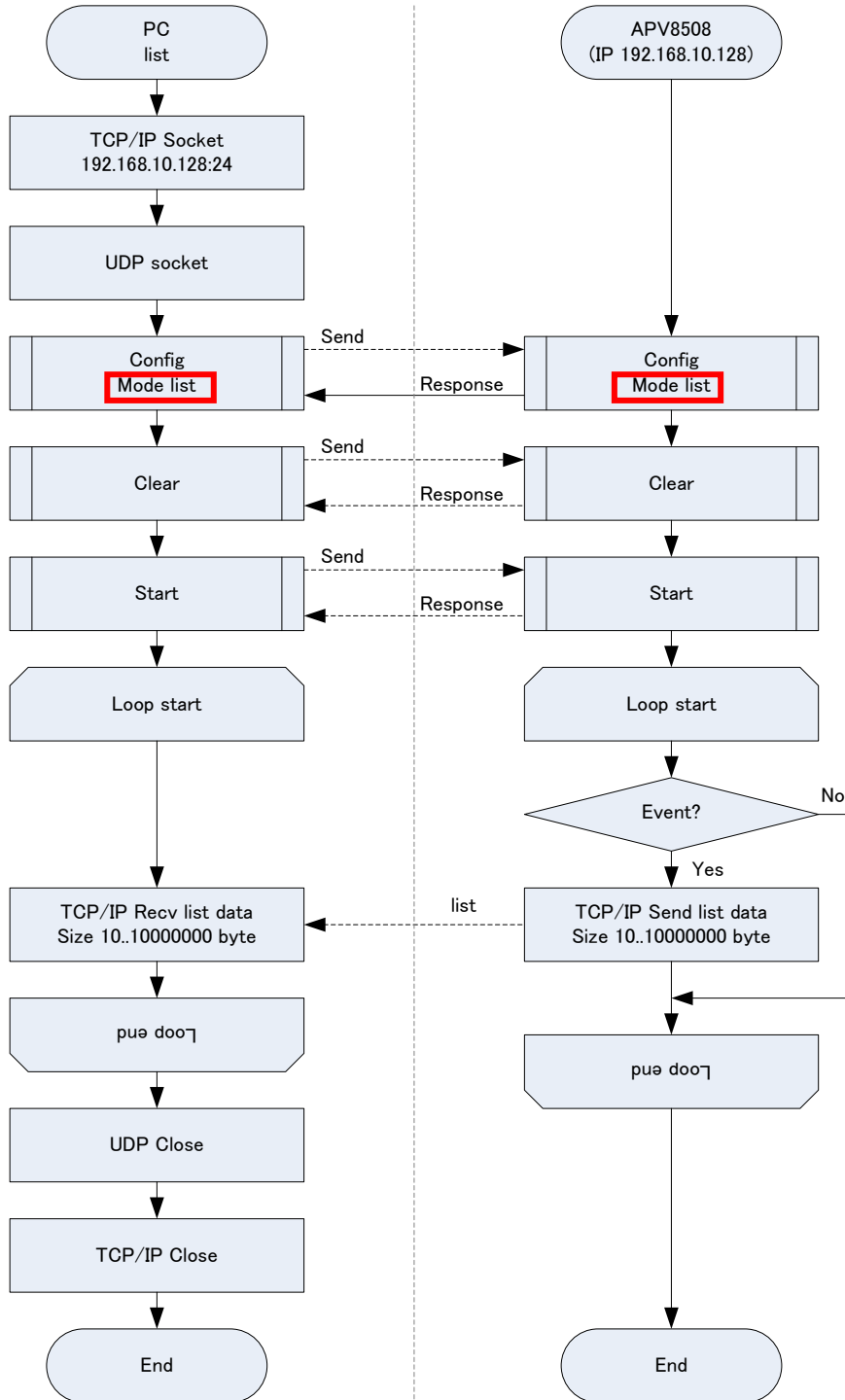

End